



# 電子產品系列 綜合型錄

## Electronic Products General Catalogue

靜電消除器  
Ionizer

無風式靜電消除器  
Room Ionizer System

靜電感測器  
Static Sensor

振動感測器  
Vibration Sensor

安全光柵  
Safety Light Curtains

| 潔淨廠房最佳方案，選用無風式靜電消除器 |

| ESD監控系統，全臺第一家完整服務現場評估、客製軟體設計及全廠施工 |

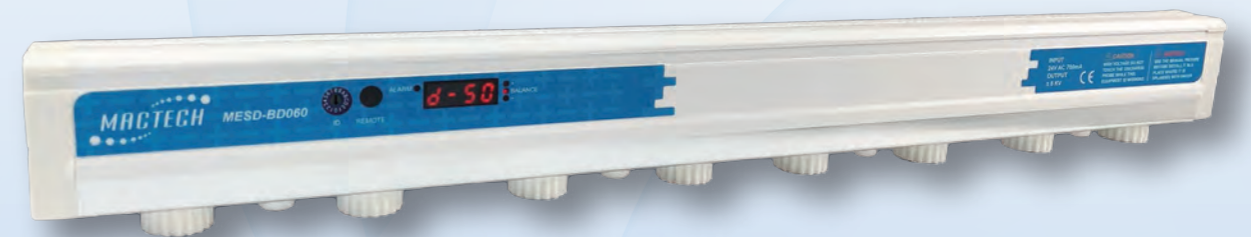

韶陽科技股份有限公司 MACTECH CORPORATION

<http://www.mactech.com.tw>

臺中市潭子區潭興路二段36巷89號

No. 89, Lane 36, Sec 2, Tanshin RD, Tanzi Dist., Taichung 427, Taiwan R.O.C

TEL:+886-4-25378884 FAX:+886-4-25386691

Mobile:+886-919-844-309

email:elec\_marketing@mactech.com.tw



本型錄資料僅供參考，最新訊息請洽詢銷售人員。 VER. 4  
All information contains in the catalogue is for reference only.



韶陽科技成立於2000年，在ISO 9001認證下設計和生產液晶顯示器及其相關之生產設備，包括Touch panel, CNC router, laser marking, IC and FPC bonding, PCB router, TFT LCD / LCM整體產線生產設備和UV系統。

於2008年，韶陽開始致力於設備與關鍵零組件的研發製造，包含靜電消除器、安全光柵、感測器(振動與靜電量測)。且提供客製化工業4.0感知層數據上傳雲端或MES的規劃整合服務，實現數據雲端化、手機監控與現場趨勢分析。及時完成和滿足客戶的需求是我們最終的目標。

Mactech Corporation was established in 2000 and we own the ISO-9001 certification. Mactech began with the goal of designing and creating automation equipment, including Touch panel, CNC router, laser marking, IC & FPC bonding, TFT LCD / LCM, PCB router and UV system.

In 2008, to improve production rate and quality, we committed to components for equipment and high-tech product using, which contains ionizer and safety light curtains. To support the innovation, we devote to Industry 4.0 application; Vibration sensor and electrostatic sensor with data collector is our new development in 2016, they provided service for integrating system with computer or PLC, to achieve data upload to Cloud or MES, mobile phone monitoring and production line state analysis. Mactech aims to fulfill the customer's requirement and complete the task in time.

- 2005~2007 參與關鍵技術產業聯盟執行電漿與相關電源技術開發  
Participating in critical technology industry alliance and developing Plasma technology.
- 2008 電漿電源延伸技術產品—靜電消除器技術研發與相關產品開發  
Plasma power extension product -- the ionizer and related product development.
- 2009 窄域管型靜電消除器 MESD-1H 產品上市  
Narrow range ionizer MESD-1H product launched.
- 2010 中域4吋風扇靜電消除器 MESD-FA04, 廣域第一代棒型靜電消除器 MESD-BA 系列產品上市  
靜電量測技術開發  
4-inch Fan type ionizer MESD-FA04 and Bar type ionizer MESD-BA launched.  
Static measurement technology develop.
- 2011 第二代管型靜電消除器 MESD-1HA, 手持式靜電量測儀 MESD-TA01 產品上市  
The second generation of Tube type ionizer MESD-1HA and Handheld electrostatic field meter MESD-TA01 launched.
- 2012 第二代棒型靜電消除器 MESD-BB 系列產品上市, 安全光柵產品開發上市。  
The second generation Bar type ionizer MESD-BB launched. Safety Light Curtains launched.
- 2013 5吋風扇型靜電消除器 MESD-FA05A 產品上市; 區域光柵產品開發上市。  
5-inch Fan type ionizer MESD-FA05A launched. Area Infrared Curtains launched.
- 2014 第三代棒型靜電消除器 MESD-BC 系列產品上市, 提升除電能力15%、降低耗氣20%, 增加串聯系統; 區域型靜電消除器 MESD-NA 系列產品上市, 進階型安全光柵產品上市  
The third generation of Bar type ionizer MESD-BC launched. The decay time promote 15%, air consumption reduce 20% and has a new function of serial connection.  
Area type ionizer MESD-NA launched. Advanced type Safety Light Curtains launched.
- 2015 槍型靜電消除器 MESD-GA 系列產品上市  
Gun type ionizer MESD-GA launched.
- 2016 工業4.0技術開發, 推出資料收集器、感測器組; 抗強光型安全光柵產品上市  
Devoted to Industry 4.0 application. Vibration sensor and Electrostatic sensor with Data collector launched.  
The Anti-glare type Safety Light Curtains launched.
- 2018 第二代區域型靜電消除器 MESD-NAP 系列產品上市  
The second generation Area type ionizer MESD-NAP launched.
- 2019 第四代棒型靜電消除器 MESD-BD 系列產品上市, 機械手臂用靜電消除器 MESD-1HB 系列產品上市, 第二代手持式靜電量測儀 MESD-TA02 產品上市, 第二代靜電感應器 MESD-SE02 產品上市  
The fourth generation of Bar type ionizer MESD-BD launched. Ionizer for Robotic Arm MESD-1HB launched. The second generation Surface DC Voltmeter MESD-TA02 and Electrostatic sensor MESD-SE02 launched.
- 2022 建構完整ESD監控方案, 包含靜電手環、設備接地、建物接地樁、軟體系統以及人員靜電進出管理。  
Build a complete ESD monitoring solution, including electrostatic wristbands, equipment grounding, building grounding stakes, software systems, and personnel ESD protection management.



■ 靜電消除原理	Static Elimination Principle	
■ 棒型靜電消除器	MESD-BC & MESD-BD	01~10
Bar Type Ionizer		
■ 區域型靜電消除器	MESD-NAP	11~16
Area Type Ionizer		
■ 扇型靜電消除器	MESD-FA	17~24
Fan Type Ionizer		
■ 管型靜電消除器	MESD-HA & MESD-HB	25~36
Tube Type Ionizer		
■ 槍型靜電消除器	MESD-GA	37~40
Gun Type Ionizer		
■ 靜電感測器	MESD-SE	41~44
Electrostatic Sensor		
■ 振動感測器	MS-VS	45~48
Vibration Sensor		
■ 監測儀錶	MD	49~50
Meter		
■ 手持式靜電量測儀	MESD-TA	51~52
Surface DC Voltmeter		
■ 手持式振動量測儀	VM-02	53~54
Handheld Vibration Meter		
■ 安全光柵	SLC	55~62
Safety Light Curtains		
■ 包材尺寸與重量		63~64
Packaging Size and Weight		



# 靜電消除原理

## 靜電產生過程

物體由原子組成, 一般情形下, 原子的質子帶正電, 電子帶負電, 並且二者呈現平衡狀態。



兩個物體接觸或發生摩擦時, 電子會從一種材料的原子轉移至另一種材料的原子中。吸引電子的材料帶負電, 失去電子的材料帶正電, 這就是靜電產生過程。

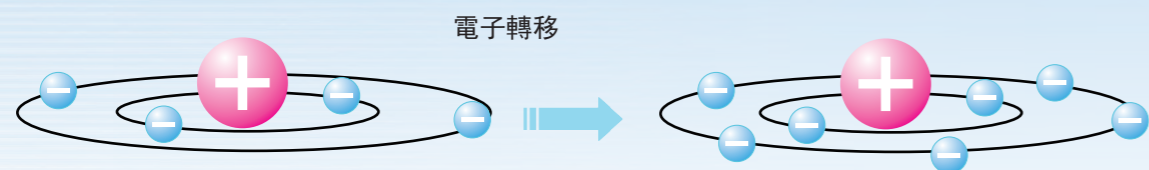

## 常見靜電產生問題

最容易產生靜電聚集的方式, 主要有以下三種作動。

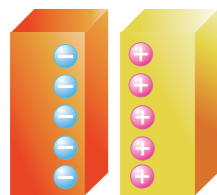

物體接觸產生靜電

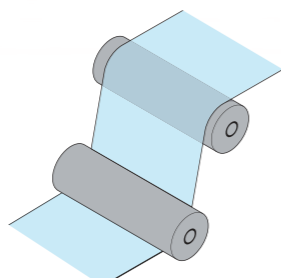

物體磨擦產生靜電

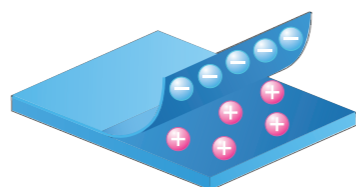

物體剝離產生靜電

## 各產業常見靜電問題

產業	帶靜電物體	靜電產生導致的問題點
半導體 面板	包裝 內部電路 設備 玻璃面板 操作人員	損傷電路 減弱特性 減少產量 晶體管受損 出廠後不良 灰塵吸附
電子	設備 操作人員 材料	電路故障 損傷電路或設備 運行中斷
化學	纖維 薄膜 膠膜	灰塵吸附 放電起火源 薄膜纏繞
其它	粉末	結塊 散亂 不易篩選 放電起火源
	運輸管道	灰塵吸附 放電起火源
	造紙印刷 食品包裝	紙張吸黏 印刷不良 包裝材吸附 人員靜電觸電

## 靜電處理方法

### 接地導電

電子可在金屬上自由移動, 因此金屬接地時便可以讓帶靜電的離子至大地中和, 人體也屬於導體, 可運用靜電腕帶、防靜電地墊以及防靜電衣服快速將靜電中和。

### 濕度控制

濕度較高時, 絕緣體表面的水分就會比較多。水可以導電降低了絕緣體的電阻, 使電荷的數量減少。

### 抗靜電材料

使用抗靜電原料與產品, 減低靜電產生。

### 靜電消除器

靜電消除器按技術可分為兩種類型, 電離輻射系統與電暈放電系統。  
電離輻射式靜電消除器產生離子方式有「軟 X 射線方式」或「紫外線方式」。  
電暈放電式靜電消除器透過針形電極來集中電場造成空氣中離子游離, 使用游離離子中和靜電達到消除靜電的目的。

## 電暈放電系統模式

### 電暈式靜電消除器原理

利用高電壓尖端放電原理: 施加高壓的針形電極、高壓電源與接地端組合, 將高壓施加到電極後, 會在針尖上產生電暈放電發生電暈放電時, 電極針周圍的空氣被分解產生正負離子。

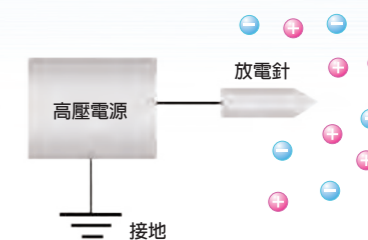

### 電暈式靜電消除器高壓電源選擇

#### 直流型電源模式

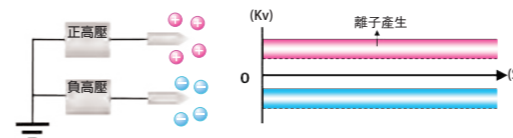

#### 高頻交流型電源模式

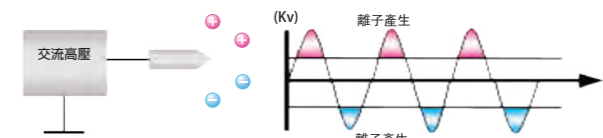

#### 脈衝直流型電源模式

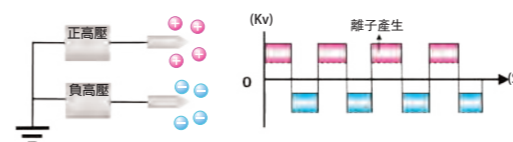

#### 脈衝交流型電源模式

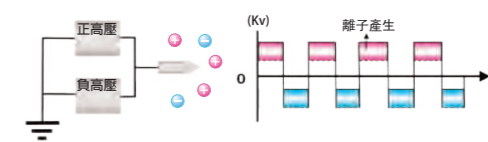

	直流型電源模式	高頻交流型電源模式	脈衝直流型電源模式	脈衝交流型電源模式
優點	產生離子數量多, 除電速度快	離子平衡性能好	產生離子數量多, 除電速度快	解離離子數量多, 除電速度快
缺點	因正負放電針消耗不一樣, 除電效能會隨使用時間大幅下降	高壓電壓值低、離子數量少, 靜電消除速度較慢。	雖提升能力改善離子平衡性差問題點, 但隨時間除電能力性能下降	因正負在相同放電針解離, 可改善隨使用時間使除電能力性能下降問題

# Static Elimination Principle

## Static Electricity Generation Process

Objects made of atoms, generally, proton of atoms is Positive electricity and Electronic of atoms is Negative electricity. Both presented a state of equilibrium

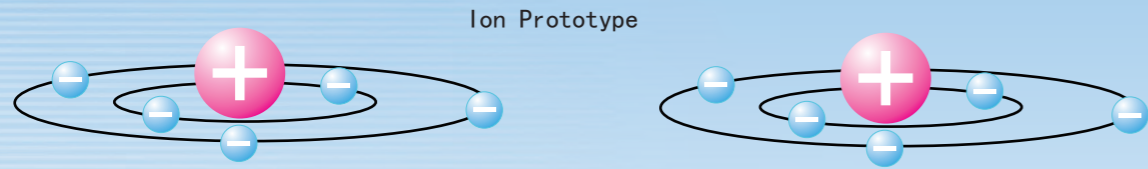

When two objects contact or friction, Electronic can move from this atom to other atom. Electron-attracting atoms is negative charged and missing electronic of atoms is positive charged. This is the static electricity generating process

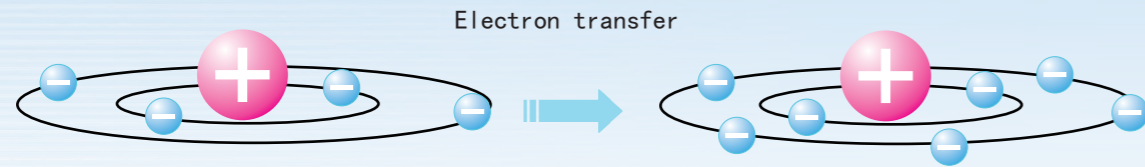

## Electrostatic Common Problems

The easiest way to generate static build, There are three main actuator.

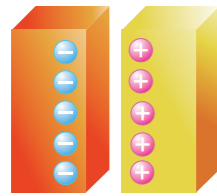

Object generate static with touching

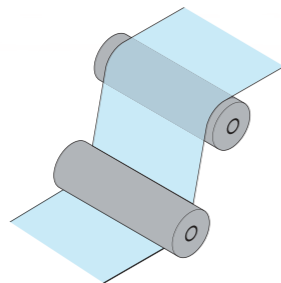

Object generate static with friction

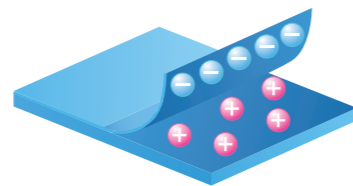

Object generate static with stripped

## Common Static Problems in All Industries

Industry	Object with static	Problems generated by electrostatic damage
Semiconductor Panel	Package \ Internal circuit \ Equipment Glass panel \ Operator	Damage circuit \ Weakening characteristic \ Reduce production Transistor damaged \ Poor factory \ Dust absorption
Electronic	Equipment \ Operator \ Material	Circuit fault \ Damage circuit or equipment \ Interruption run
Chemistry	Fiber \ Film \ Coating	Dust absorption \ Discharge fire \ Film winding
Other	Powder	Agglomeration \ Scattered \ Screening is not easy \ Discharge fire
	Pipelines	Dust absorption \ Discharge fire
	Paper	Paper absorb \ Bad printing
	Package	Packing material absorption \ Personnel electrostatic shock

## Static Process Approach

### Grounded Conductive

Electronic can be freedom of movement in the metal. When the metal connect ground, the electrostatic ion move to ground and become electrically neutral. Human body also belong conductor. It can use static wrist strap, anti-static mats and anti-static clothes to neutralize static electricity quickly

### Humidity Control

When the humidity is higher, surface water of insulator can be more. Water can lower insulation resistance that reduce number of charge

### Antistatic Materials

Use antistatic materials and products to reduce static electricity

### Ionizer

Technology of ionizer can be divided into two types that radiation system and discharge system. Radiant type of ionizer produce ions with soft X-ray or ultraviolet rays. Corona type ionizer use needle discharge to ion free. Using electrostatic ion to arrive at static elimination

## Corona Discharge System Model

### Corona Type Ionizer Produce Principle

Using high voltage to needle discharge. Ionizer is composed of element, electrode probe, high voltage power and ground. Before it use high voltage to probe electrode, it produce corona discharge, then air around the electrode probe is decomposed to produce ions

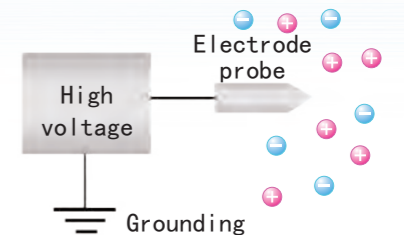

### Corona Type Ionizer's Choice of Hi-voltage Power Supply

#### DC Power Model

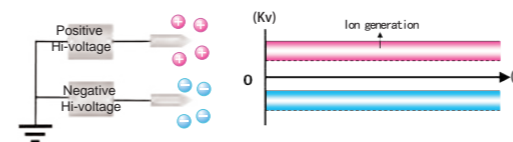

#### High frequency AC Power Model

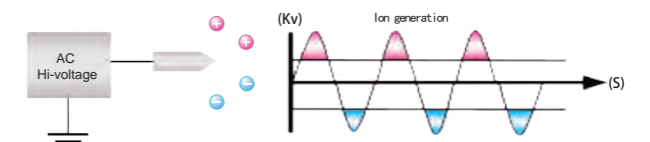

#### Pulse DC Power Model

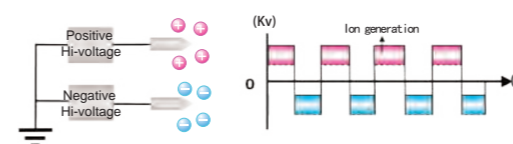

#### Pulse AC Power Model

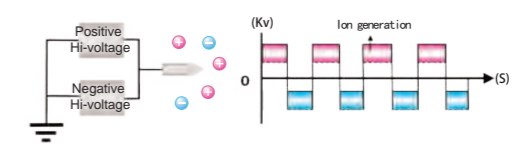

	DC Power Model	High frequency AC Power Model	Pulse DC Power Model	Pulse AC Power Model
Advantage	Discharging ion quantity are many and static elimination speed is fast	Ion balance performance is very good	Ionizer discharge a lot of ion and static elimination speed is fast	Ionizer discharge a lot of ion and static elimination speed is very fast
Defect	Because positive and negative needles' consume is different, static elimination speed will reduce substantially with the use of time	Because high voltage value is lower, the amount of ion is lower and static elimination speed reduce	Although it improve the static elimination speed and balance performance, but also static elimination speed reduce substantially with the use of time	Because positive and negative power discharge in the same needle, it improve problem substantially that static elimination speed reduce with the use of time



# 廣域高速型靜電消除器 MESD-BD Wide Range Ionizer

- 棒型  
Bar Type
- 區域型  
Area Type
- 扇型  
Fan Type
- 管型  
Tube Type
- 槍型  
Gun Type

- 棒型  
Bar Type
- 區域型  
Area Type
- 扇型  
Fan Type
- 管型  
Tube Type
- 槍型  
Gun Type



高度縮減省空間  
Reduce the height

側邊電源插座設計  
Side-Input power hole



內建通訊埠量測靜電  
Built-in static sensor port

## 快速高壓脈衝AC模式 High Voltage Pulse AC Mode

在單電極針上施加正負高壓，有效提升電離子生成量，實現高速靜電消除效果，與傳統AC相比可更有效提高離子生成。  
Inflicting +/- high voltage on the electrode probe, efficiently increasing the amount of ions generated, achieve high-speed static elimination, compared with the conventional AC mode generation can be more effectively improved.

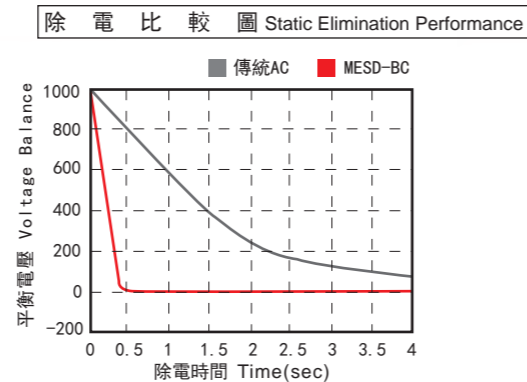
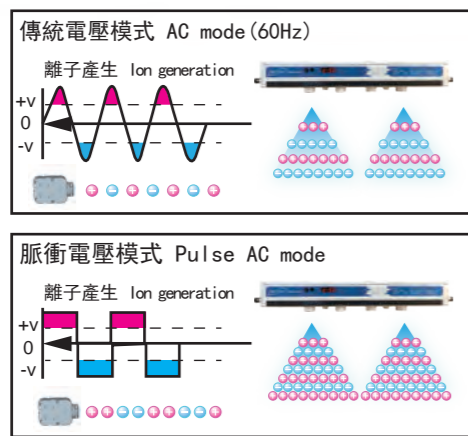

除電比較圖 Static Elimination Performance  
測試條件 距離 30cm Test Conditions Distance 30cm  
±1000V到±100V消除靜電所需時間 Elimination time: From ±1000V to ±100V  
使用150mm x 150mm CPM (20pF) Use 150mm x 150mm (20pF) CPM device

## 高度的離子平衡 Excellent Ion Balance

利用脈衝AC電源搭配自我偵測高壓平衡系統，可以有效提高離子平衡度，離子平衡±30V。  
Using pulsed AC voltage with self-detection balance of high-voltage system that can effectively improve the ion balance up to ±30V, with appropriate conditions and status can be achieved within ±15V.

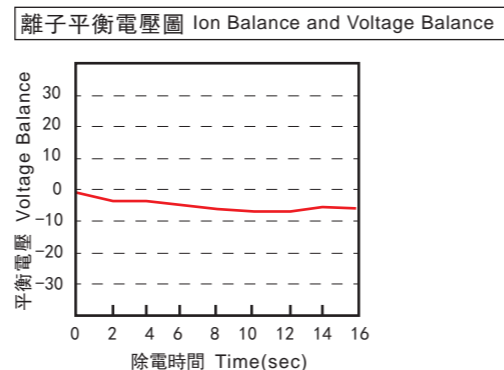
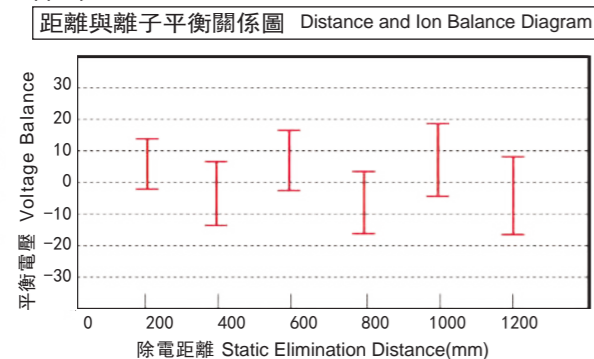

## 多樣化選擇 Variety of Lengths

支援各世代玻璃基板，最長可到3米範圍。Support every generation glass substrate.

型號 Model	支援玻璃世代 Generation
MESD-BD036	-
MESD-BD060	G1-G2
MESD-BD084	G3
MESD-BD108	G4
MESD-BD132	G5
MESD-BD156	-
MESD-BD180	-
MESD-BD204	G6
MESD-BD228	G7
MESD-BD252	G8
MESD-BD300	G9

## 遠端遙控器 Remote Control

1對16的遠端遙控功能，具有3米的遙控距離，讓您輕鬆應用。  
The function of 1 to 16 bar remote control with the distance of 3 meter, makes it easy use.

## 可調式離子比例 Adjustable Ion Duty

可調多段離子比例，依環境需求調整離子比例，達到最佳除電效果。  
Adjustable ion duty, it depends on working environment and temperature to achieve the best efficiency.

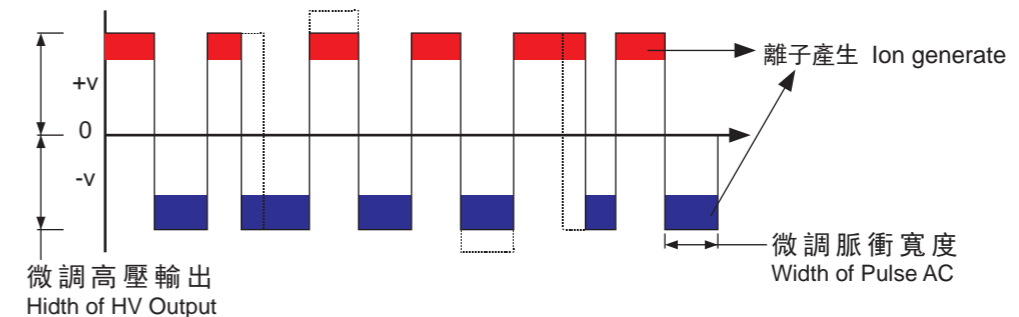

## 可調式輸出高壓頻率 Adjustable Frequency of Output Voltage

可切換10段頻率，實現近至100mm，遠至1500mm範圍內最適合的靜電消除環境；從近距離到遠距離都能達到最佳除電效果。  
The output of 10 stage adjustable frequency of high voltage, the range of static elimination is from 100mm to 1500mm.



## 支援工業4.0線上監控 Support Industry 4.0 online monitoring

支援Modbus RTU通訊格式傳輸，結合工業4.0感知層，雲端輕鬆監控。  
Support Modbus RTU communication format transmission, combined with industrial 4.0 sensing layer, easy to cloud monitor.

棒型  
Bar Type

區域型  
Area Type

扇型  
Fan Type

管型  
Tube Type

槍型  
Gun Type

## 產品特色 Features

### 高速噴嘴設計 High Speed Nozzle Design

多出氣孔的設計使除靜電範圍更寬，且較單出氣孔主機範圍更廣，同時多支針產生離子讓靜電消除更快速。

Many of the nozzles design improve the range of static elimination and speed up to neutralize static on the object.



### 快拆式放電針 Quick Release Electrode Probe

快拆式設計可讓使用者輕鬆更換電極針，減少維護步驟，有效節省維護時間。

Quick released nozzle helps user to replace the electrode probe simply, reduce the maintenance process, moreover save time.



### 配置顯示視窗，監控輸出平衡 Mounted Indicator, Control Ion Balance

輸出離子是否平衡，監控資訊在LED顯示器一目了然。

LED display shows ion balance of output.



### 低電壓DC24V輸入 Input of DC24V Low Voltage

可有效避免放電所造成纜線老化與對週遭的裝置影響，建構高可靠性系統。

Which can prevent cables gradually aging by the static discharge with high reliable system.

## 規格 Specifications

項目 Items	規格 Specifications	
使用流體 Air Flow	乾燥壓縮空氣 Compressed Dry Air	
輸入電源 Input Power	DC 24V ±5%	
消耗電流 Current Consumption	Approximate 700 mA	
出力電源 Applied Voltage	±8KV (MAX)	
離子平衡 Ion Balance	±30V (距離 Distance 300 mm)	
建議設置距離 Operating Distance	100~1500 mm	
介面顯示 LED Indicator	離子狀態 Ion Status	顯示離子正負平衡 Ion ± balance
	異常顯示 Alarm Show	異常時紅燈亮 LED turns on red light
	離子設定 Ion Setting	顯示設定比例與頻率 Setting ion duty and frequency
異常輸出接點 Power Safety Circuit	NPN電晶體出力 NPN transistor output (Max. 24 mA)	
壓縮空氣耗流量 CDA Consumption	95~390 l/min (0.2 MPa)	
使用壓力範圍 Air Pressure Range	0.1~0.5 Mpa	
使用環境溫度 Ambient Temperature	15~40°C (室內 Indoor)	
使用環境溼度 Ambient Humidity	35~65% RH (無冷凝 No condensation)	

## 外觀尺寸 External Dimensions

單位 Unit: mm

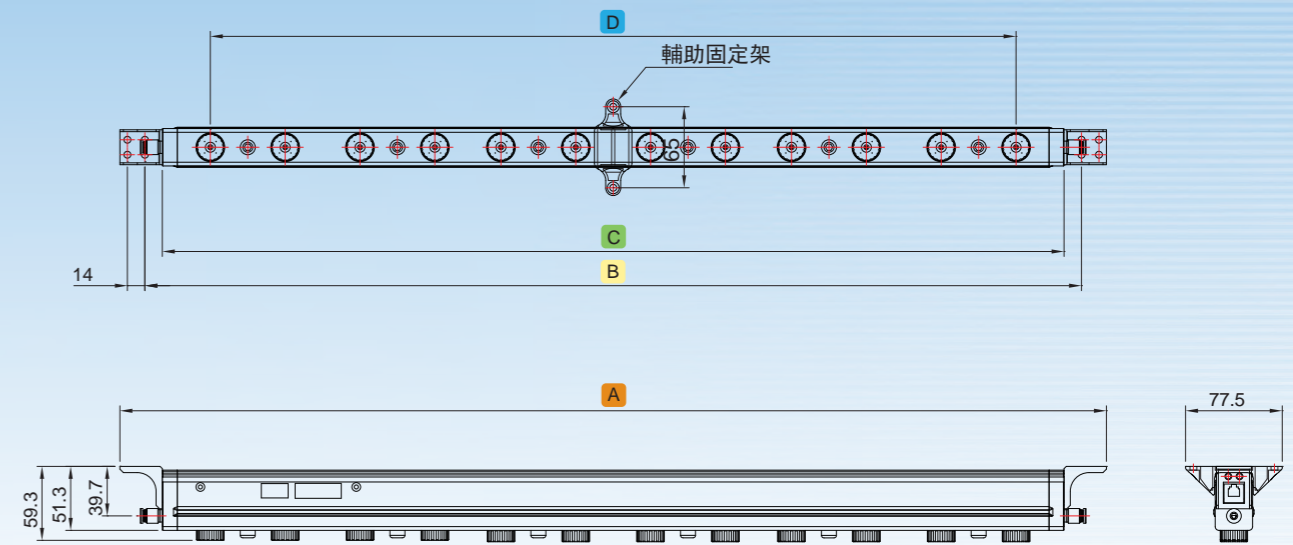

建議設置距離 Operating Distance: 100mm~1500mm

型號 Model	A 總長 Total Length	B 安裝間距 Install Distance	C 靜電消除棒長度 Bar Length *	D 電極間距和長度 Electrode Spacing and Length	中間固定架數量 No. of Auxiliary Fixtures	放電針數量 No. of Probes	管接頭 Tube Fitting
MESD-BD036	424	384	356	180	0	4	Ø6
MESD-BD060	558	518	490	413	0	8	Ø6
MESD-BD084	791	751	723	646	0	12	Ø6
MESD-BD108	1024	984	956	879	1	16	Ø6
MESD-BD132	1257	1217	1189	1112	1	20	Ø6
MESD-BD156	1490	1450	1422	1345	1	24	Ø8
MESD-BD180	1723	1683	1655	1578	2	28	Ø8
MESD-BD204	1956	1916	1888	1811	2	32	Ø8
MESD-BD228	2189	2149	2121	2044	2	36	Ø8
MESD-BD252	2422	2382	2354	2277	3	40	Ø8
MESD-BD300	2888	2848	2820	2743	3	48	Ø8

\* 靜電消除棒長度等同除電有效長度。The bar length equal static elimination length.  
以上資料僅供參考，實際數據以現場測試狀況為準。  
The above information is for reference only. The actual data to field test shall prevail.



# 廣域高速型靜電消除器 MESD-BC Wide Range Ionizer

- 棒型  
Bar Type
- 區域型  
Area Type
- 扇型  
Fan Type
- 管型  
Tube Type
- 槍型  
Gun Type



## 外觀尺寸 External Dimensions

單位 Unit: mm

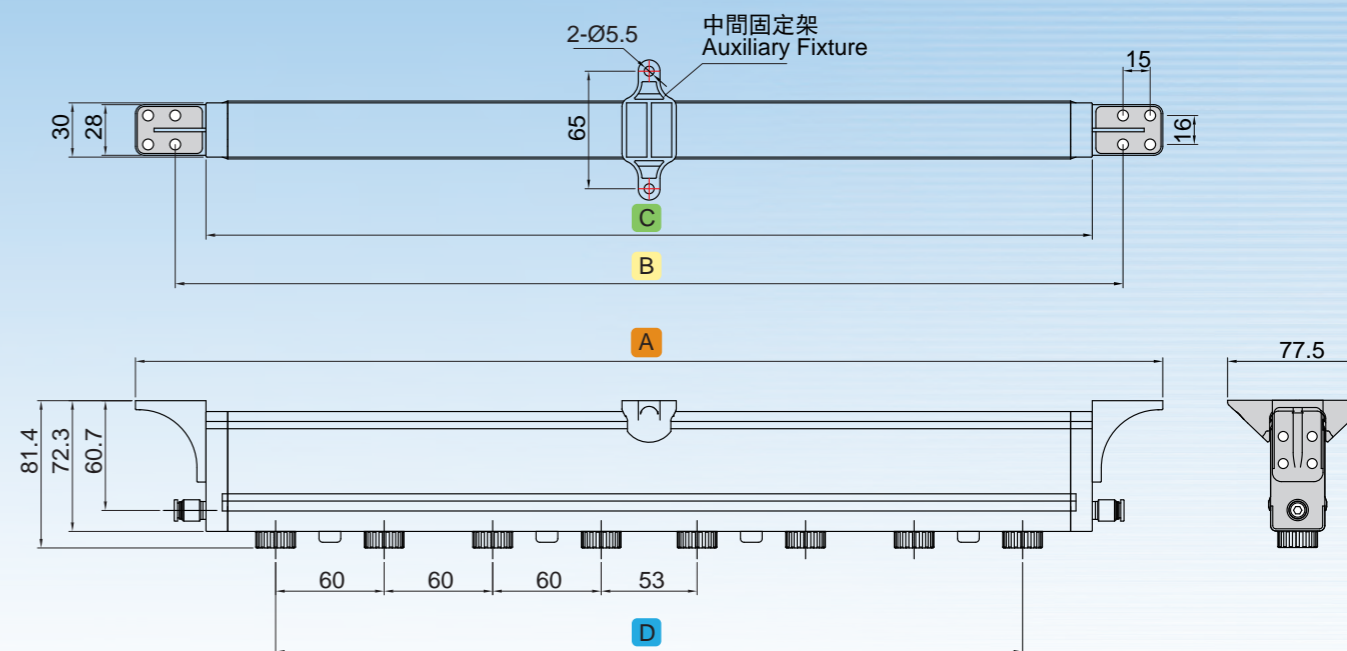

- 棒型  
Bar Type
- 區域型  
Area Type
- 扇型  
Fan Type
- 管型  
Tube Type
- 槍型  
Gun Type

## 規格 Specifications

項目 Items	規格 Specifications	
使用流體 Air Flow	乾燥壓縮空氣 Compressed Dry Air	
輸入電源 Input Power	DC 24V ±5%	
消耗電流 Current Consumption	Approximate 350 mA	
出力電源 Applied Voltage	±6.5KV (MAX)	
離子平衡 Ion Balance	±30V (距離 Distance 300 mm)	
建議設置距離 Operating Distance	100~1500 mm	
介面顯示 LED Indicator	離子狀態 Ion Status	顯示離子正負平衡 Ion ± balance
	異常顯示 Alarm Show	異常時紅燈亮 LED turns on red light
	離子設定 Ion Setting	顯示設定比例與頻率 Setting ion duty and frequency
異常輸出接點 Power Safety Circuit	NPN電晶體出力 NPN transistor output (Max. 24 mA)	
壓縮空氣耗流量 CDA Consumption	95~390 l/min (0.2 MPa)	
使用壓力範圍 Air Pressure Range	0.1~0.5 Mpa	
使用環境溫度 Ambient Temperature	15~40°C (室內 Indoor)	
使用環境溼度 Ambient Humidity	35~65% RH (無冷凝 No condensation)	

型號 Model	A 總長 Total Length	B 安裝間距 Install Distance	C 靜電消除棒長度 Bar Length *	D 電極間距和長度 Electrode Spacing and Length	中間固定架數量 No. of Auxiliary Fixtures	放電針數量 No. of Probes	管接頭 Tube Fitting
MESD-BC036	434	390	356	180	0	4	Ø6
MESD-BC060	568	524	490	413	0	8	Ø6
MESD-BC084	801	757	723	646	0	12	Ø6
MESD-BC108	1034	990	956	879	1	16	Ø6
MESD-BC132	1267	1223	1189	1112	1	20	Ø6
MESD-BC156	1500	1456	1422	1345	1	24	Ø8
MESD-BC180	1733	1689	1655	1578	2	28	Ø8
MESD-BC204	1966	1922	1888	1811	2	32	Ø8
MESD-BC228	2199	2155	2121	2044	2	36	Ø8
MESD-BC252	2432	2388	2354	2277	3	40	Ø8
MESD-BC300	2898	2854	2820	2743	3	48	Ø8

\* 靜電消除棒長度等同除電有效長度。The bar length equal static elimination length.  
以上資料僅供參考，實際數據以現場測試狀況為準。  
The above information is for reference only. The actual data to field test shall prevail.

- 棒型  
Bar Type
- 區域型  
Area Type
- 扇型  
Fan Type
- 管型  
Tube Type
- 槍型  
Gun Type

配件 Accessories

棒型標準配件  
Bar Type Package Content

- ▶ 遙控器 Remote Control  
MESD-BR201
- ▶ 棒型電纜線 Power Cable (3 meter)  
MESD-CP021
- ▶ 中間固定架 Auxiliary Fixture  
MESD-BF601



- ▶ 管接頭 Tube Fitting Ø6 / Ø8  
CRL0000680 / CRL0000144
- ▶ BC固定支架 End Bracket  
MESD-BF602
- ▶ BD固定支架 End Bracket  
MESD-BF604



選購配件  
Options Parts

- ▶ 噴嘴 Auxiliary Nozzle  
MESD-BP302
- ▶ BC旋轉支架 Rotation Bracket  
MESD-BF603
- ▶ BD旋轉支架 Rotation Bracket  
MESD-BF605



耗材選購配件  
Consumable Options

- ▶ 棒型放電針 Electrode Probe  
MESD-BP301



(使用壽命：約8,000小時)  
(Life time: about 8,000 hrs)

電源選購配件  
Power Supply Options

- ▶ 棒型電源供應器 Power Supply 60W  
MESD-CP060E



- ▶ 中間固定架 Auxiliary Fixture  
MESD-BF601

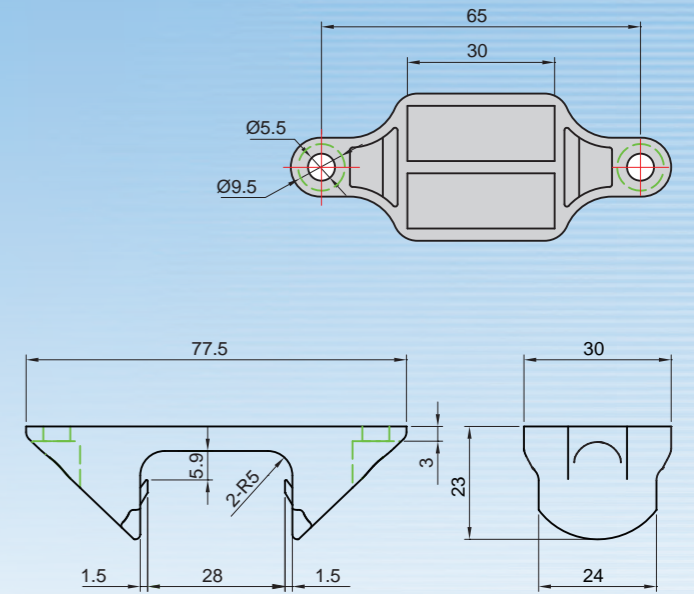
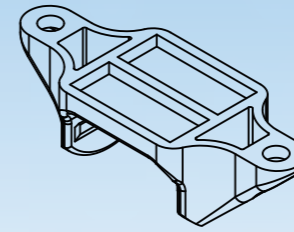

- ▶ 棒型固定支架 End Bracket  
MESD-BF602

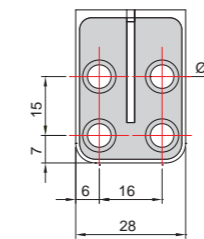
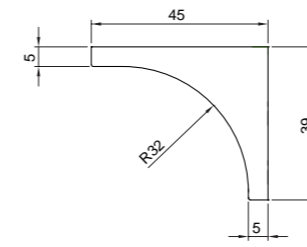
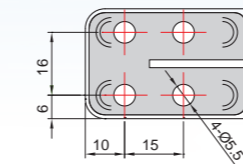

MESD-BF604

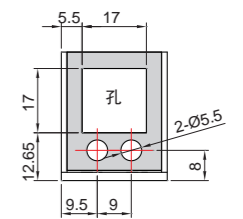
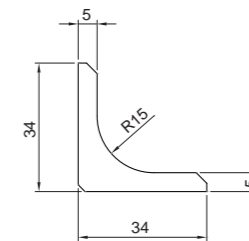
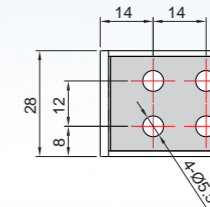

- ▶ 旋轉支架 Rotation Bracket  
MESD-BF603

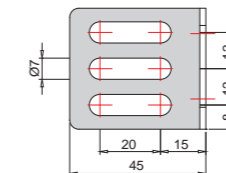
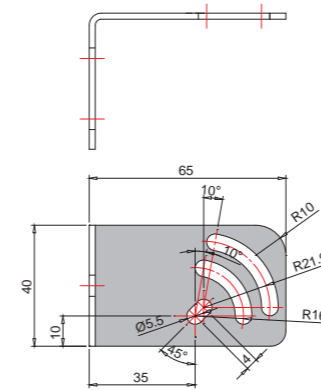

MESD-BF605

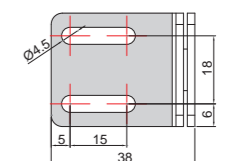
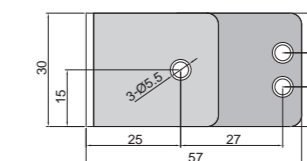
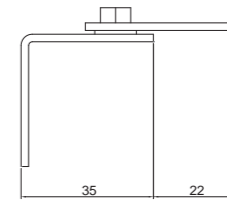

- 棒型  
Bar Type
- 區域型  
Area Type
- 扇型  
Fan Type
- 管型  
Tube Type
- 槍型  
Gun Type



棒型  
Bar Type

區域型  
Area Type

扇型  
Fan Type

管型  
Tube Type

槍型  
Gun Type

性能曲線圖 Static Elimination Performance

靜電消除區域與時間 Decay time(0.2MPa)

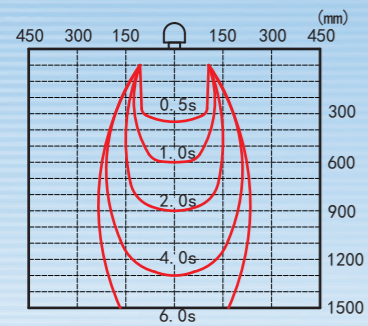

測試條件:  
· 電壓在±1000V到±100V範圍內的靜電消除時間  
· 使用150mm x 150mm (20pF) 平板測試儀  
· 使用MESD-BC108, MESD-BD108  
· 空氣壓力0.2MPa . 無下降氣流

Test Conditions :  
Ion static elimination time:  
From voltage ±1000V to ±100V  
Use 150mm x 150mm (20pF) CPM device  
Use MESD-BC108, MESD-BD108  
CDA 0.2Mpa No downdraft

靜電消除區域與時間 Decay time(0.5MPa)

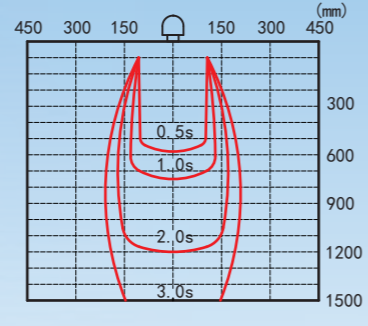

測試條件:  
· 電壓在±1000V到±100V範圍內的靜電消除時間  
· 使用150mm x 150mm (20pF) 平板測試儀  
· 使用MESD-BC108, MESD-BD108  
· 空氣壓力0.5MPa . 無下降氣流

Test Conditions :  
Ion static elimination time:  
From voltage ±1000V to ±100V  
Use 150mm x 150mm (20pF) CPM device  
Use MESD-BC108, MESD-BD108  
CDA 0.5Mpa No downdraft

靜電消除區域與時間 Decay time(0.2MPa)

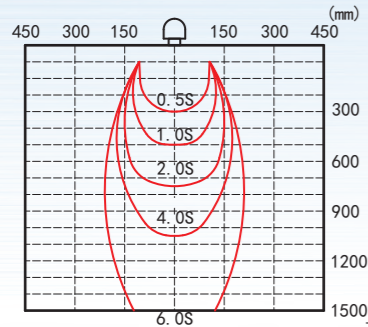

測試條件:  
· 電壓在±1000V到±100V範圍內的靜電消除時間  
· 使用150mm x 150mm (20pF) 平板測試儀  
· 使用MESD-BC180, MESD-BD180  
· 空氣壓力0.2MPa . 無下降氣流

Test Conditions :  
Ion static elimination time:  
From voltage ±1000V to ±100V  
Use 150mm x 150mm (20pF) CPM device  
Use MESD-BC180, MESD-BD180  
CDA 0.2Mpa No downdraft

靜電消除區域與時間 Decay time(0.5MPa)

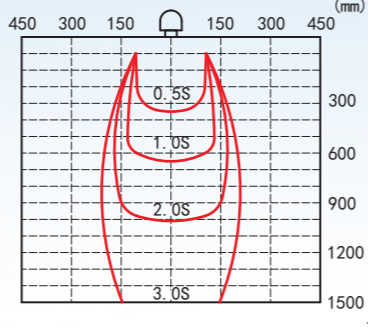

測試條件:  
· 電壓在±1000V到±100V範圍內的靜電消除時間  
· 使用150mm x 150mm (20pF) 平板測試儀  
· 使用MESD-BC180, MESD-BD180  
· 空氣壓力0.2MPa . 無下降氣流

Test Conditions :  
Ion static elimination time:  
From voltage ±1000V to ±100V  
Use 150mm x 150mm (20pF) CPM device  
Use MESD-BC180, MESD-BD180  
CDA 0.5Mpa No downdraft

靜電消除區域與時間 Decay time(0.2MPa)

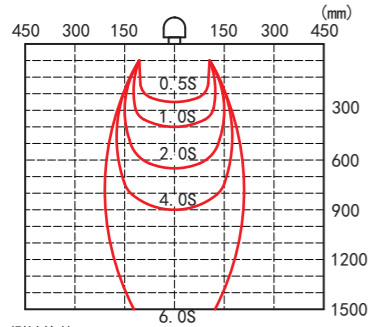

測試條件:  
· 電壓在±1000V到±100V範圍內的靜電消除時間  
· 使用150mm x 150mm (20pF) 平板測試儀  
· 使用MESD-BC252, MESD-BD252  
· 空氣壓力0.2MPa . 無下降氣流

Test Conditions :  
Ion static elimination time:  
From voltage ±1000V to ±100V  
Use 150mm x 150mm (20pF) CPM device  
Use MESD-BC252, MESD-BD252  
CDA 0.2Mpa No downdraft

靜電消除區域與時間 Decay time(0.5MPa)

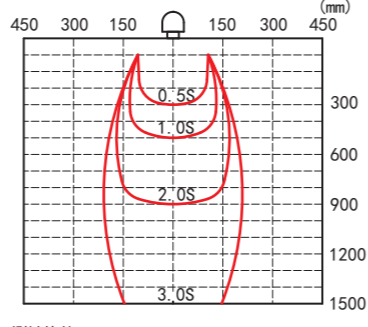

測試條件:  
· 電壓在±1000V到±100V範圍內的靜電消除時間  
· 使用150mm x 150mm (20pF) 平板測試儀  
· 使用MESD-BC252, MESD-BD252  
· 空氣壓力0.2MPa . 無下降氣流

Test Conditions :  
Ion static elimination time:  
From voltage ±1000V to ±100V  
Use 150mm x 150mm (20pF) CPM device  
Use MESD-BC252, MESD-BD252  
CDA 0.5Mpa No downdraft

耗氣量曲線圖 CDA Consumption Diagram

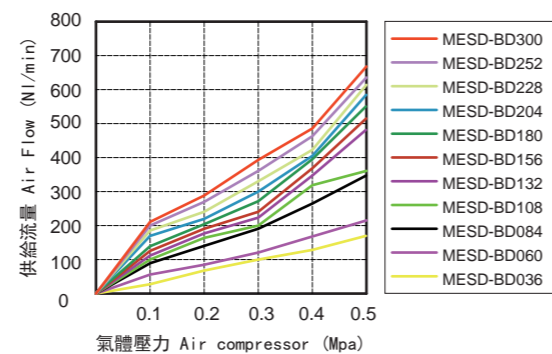
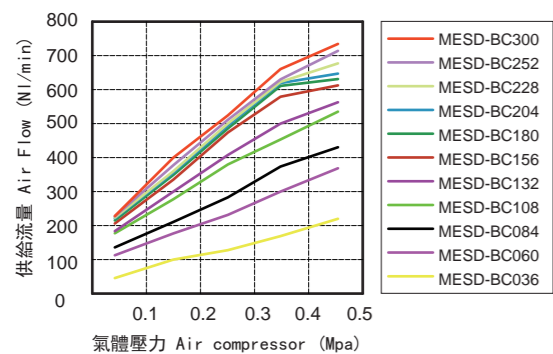

應用實例 Applications

棒型  
Bar Type

區域型  
Area Type

扇型  
Fan Type

管型  
Tube Type

槍型  
Gun Type

► 應用於機器手臂搬運系統  
Machine Transferred

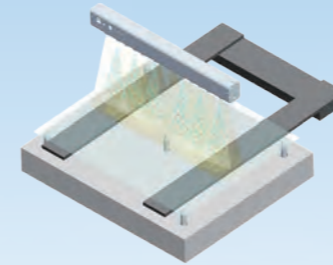

► 撕膜膠帶靜電消除  
Peeling Films Static Prevent

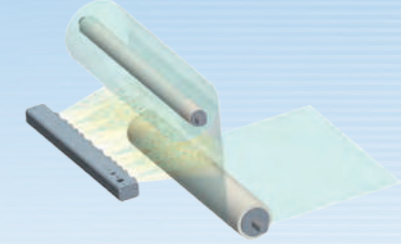

► 反式貼片機靜電消除  
Lamination / Touch Panel

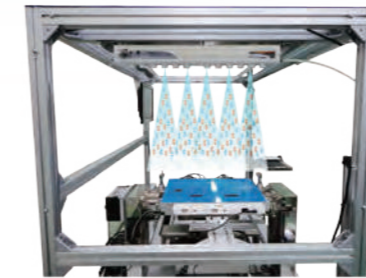

► 防止食品容器附著髒污  
Food Container Particle

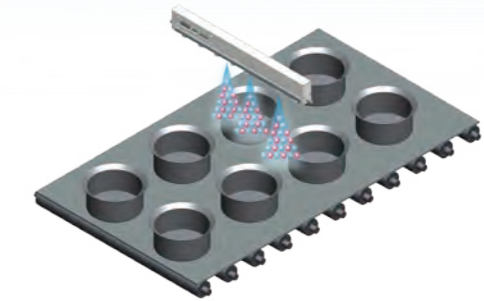

► 防止晶圓附著髒污  
Wafer Particle

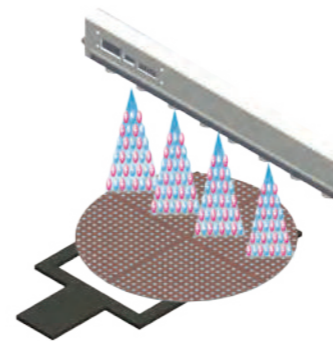

► 防止玻璃附著髒污  
Glass and Panel Particle

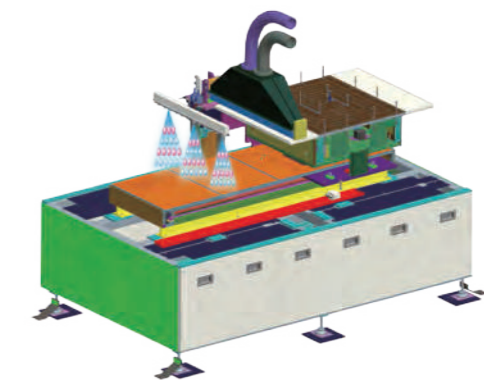



# 區域無風型靜電消除器 MESD-NAP Room Ionizer System

- 棒型  
Bar Type
- 區域型  
Area Type
- 扇型  
Fan Type
- 管型  
Tube Type
- 槍型  
Gun Type



## 脈衝與穩態DC模式 Pulse, Steady-state DC Mode

在單電極針上施加正負高壓，有效提升電離子生成量，實現高速靜電消除效果，與傳統AC相比可更有效提高離子生成。  
Inflicting +/- high voltage on the electrode probe, efficiently increase ion generation to enhance the amount of ions generated, to achieve static elimination effectively, compared with the conventional AC mode generation can be more effective improved.

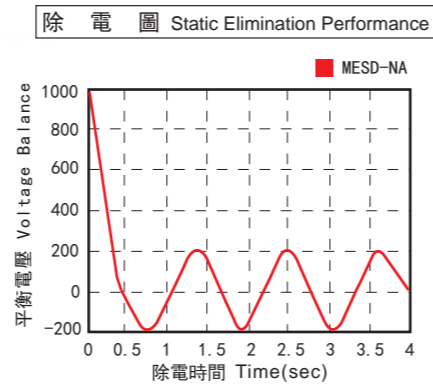
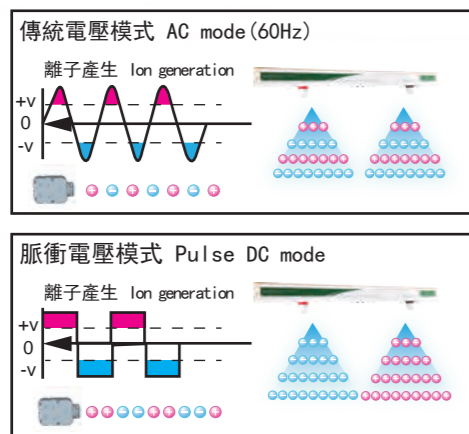

測試條件 距離 30cm Test Conditions Distance 30cm  
±1000V到±100V消除靜電所需時間 Elimination time : From ±1000V to ±100V  
使用150mm x 150mm CPM (20pF) Use 150mm x 150mm (20pF) CPM device

## 實現無靜電空間 Achieve Static-free Space

季節變換時易發生由靜電引起的各式不良問題，設備要穩定運轉靜電對策是不可缺少的。  
空間型MESD-NA對整個作業空間進行空間中的靜電抑制，使作業環境維持低靜電空間。  
All kinds of bad problems caused by static electricity when seasonal changes, to stabilize the operation of the electrostatic equipment is indispensable. The area type for the entire work space static suppression, in order to keep environment a low static space.

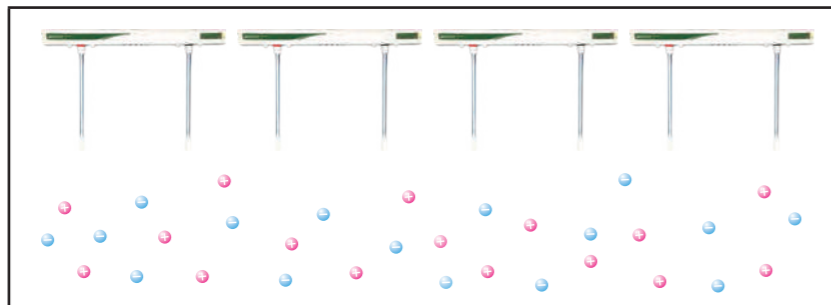

- 棒型  
Bar Type
- 區域型  
Area Type
- 扇型  
Fan Type
- 管型  
Tube Type
- 槍型  
Gun Type



## 無擾流空間 Non Interfere Space

無需連接空壓也可有效建造抗靜電空間，並且有效降低揚塵問題。  
Without Compressor can also build an antistatic space, and reducing the dust problem effectively.

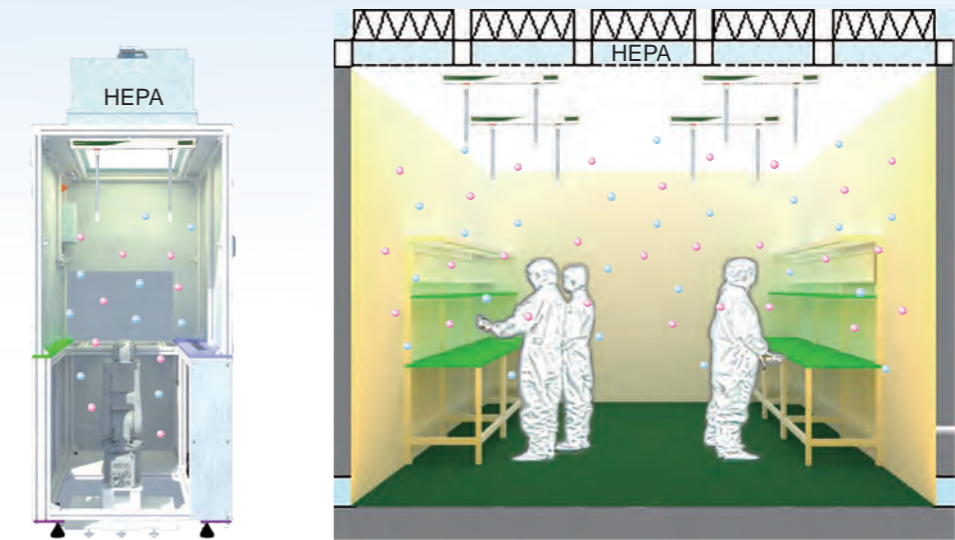

## 產品特色 Features

獨特的APC高精度迴授控制設計，達到長時間、高穩定性的平衡能力。  
The unique APC high-precision feedback control design achieves long-term, high-stability balance capability.

### 快拆式放電針 Adjustable Output Parameters

快拆式放電針設計可讓使用者輕鬆更換，減少維護步驟，有效節省維護時間。  
放電針清針提醒、衰退趨勢預判。  
The quick-disconnect discharge needle design allows users to easily replace it, reducing maintenance steps and effectively saving maintenance time. Discharge needle clearing reminder and prediction of decline trend.

### 監控操作狀態 Mounted Controller

通過連接到控制器，可監控操作狀態，減少偵測及維修時間。  
By connecting to the controller, the operating status can be monitored, reducing detection and maintenance time.

### 整合工業4.0 Choices of Electrode Probe

整合工業4.0感知層，可連結網路，即時監控。  
Integrate Industry 4.0 perception layer, can connect to the network, real-time monitoring.



棒型  
Bar Type

區域型  
Area Type

扇型  
Fan Type

管型  
Tube Type

槍型  
Gun Type

## 規格 Specifications

項目 Items	規格 Specifications
輸入電源 Input Power	AC 24V, 50/60 Hz, 1W
輸出電流 Output Current	< 20mA (內建監控回路 built-in monitoring circuit)
出力電源 Applied Voltage	DC 0~±20 KV
設定方式 Setting Method	使用遙控器MESD-NAR, 或PC監控軟體 Use MESD-NAR or PC monitoring software
連接器 Connector	RJ-11 6P4C
輸出控制 Output Control	通過獨立調節每個發射極的每個極性的離子發射電流來實現輸出和平衡穩定性 Output and balance stability are achieved by independently adjusting the ion emission current of each polarity of each emitter
離子發射週期 Ion Emission Period	最小0.1秒, 最大10秒, 可單獨設置正負離子 Min 0.1, Max 10sec, positive and negative ions can be set individually
操作模式 Operation Mode	脈衝直流、穩態直流或休眠 Pulse DC, steady-state DC or sleep mode
放電針 Discharge Needle	鈦合金、單晶矽(選配) Titanium alloy, single crystal silicon(optional)
警報 Alarm	當放電針無法保持預設的離子輸出水平時警報動作: 紅燈亮、控制器繼電器輸出 The alarm action when the ions couldn't maintain the default: the red LED turns on, the controller relay output.
臭氧量 Ozone Amount	< 0.005 ppm
潔淨度相應 Cleanliness Level	ISO Class 1
使用環境溫度 Ambient Temperature	-30~85°C (室內 Indoor)
使用環境溼度 Ambient Humidity	35~65% RH (無冷凝 No condensation)

## 外觀尺寸 External Dimension

單位 Unit: mm

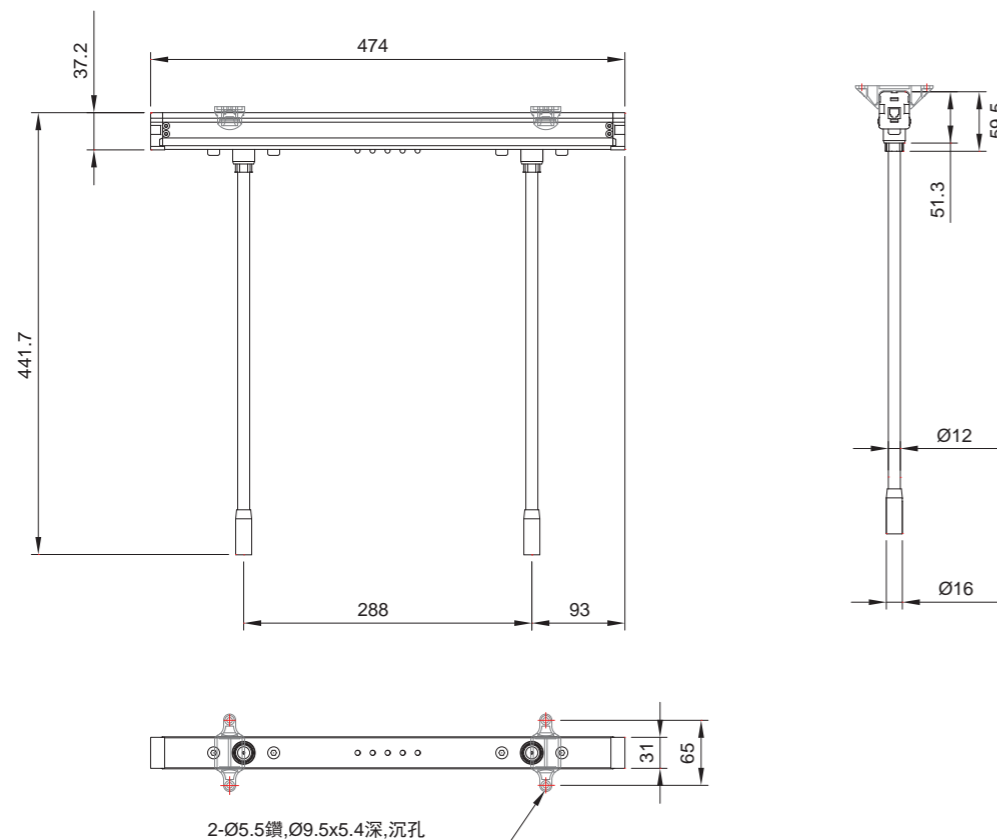

## 配件 Accessories

棒型  
Bar Type

區域型  
Area Type

扇型  
Fan Type

管型  
Tube Type

槍型  
Gun Type

## 控制器 MESD-NAQ

控制器可以輕鬆監測、分析預判。  
The controller can easily monitor, analyze and predict data.



- 控制器直接支援MODBUS RTU格式, 工程師可自行應用。  
The controller directly supports the MODBUS RTU format, which engineers can apply by themselves.
- 完整軟件系統(選配), 可直接讀寫Server數據庫, 實現離子系統與MES數據對接功能。  
Complete software system (optional), could directly read and write the Server database, Realize the data docking function between ion system and MES.
- 可外網連線、手機監看系統完整訊息。  
The complete information of the system can be monitored by external network connection and mobile phone.
- 根據實際需求, 選擇適合的控制器。  
According to actual needs, select the appropriate controller.

項目 Items	規格 Specifications
輸入電源 Input Power	AC 110V/220V ±10%
出力電源 Applied Voltage	AC 24V
通訊功能 Protocol	Modbus RTU(RS485)
輸出警報 Output Mode	繼電器 Relay
尺寸 Size	336 x 92 x 91 mm
重量 Weight	MESD-NAQ: 3.0 kg; MESD-NAQ-S: 2.3 kg

\*MESD-NAQ-S: 安裝數低於20組 (Less than 20 sets).  
\*MESD-NAQ: 最大安裝數達80組 (Up to Max. 80 sets).

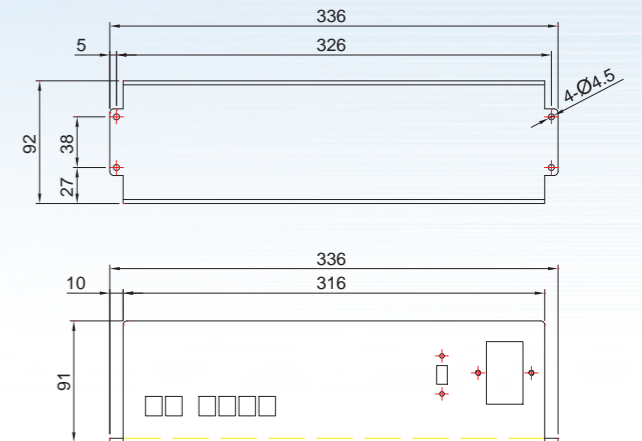

## 遙控器 MESD-NAR

遙控器可以控制靜電消除器及控制器。  
The remote control can control the static eliminator and the controller.



- 內建多國語言(英文/簡體中文/繁體中文)更易操作。  
Built-in multi-language (English/Simplified Chinese/Traditional Chinese) is easier to operate.
- 可直接設定靜電消除器(NAP)與控制器(NAQ)。  
The static eliminator (NAP) and controller (NAQ) can be set directly.

項目 Items	規格 Specifications
輸入電源 Input Power	1.5V 3號電池(AA)*2
通訊功能 Protocol	Modbus RTU(RS485)
顯示器 Display	單色LCD 白色背光
尺寸 Size	130*76*32 mm
重量 Weight	340 g (不含電池 Without battery)

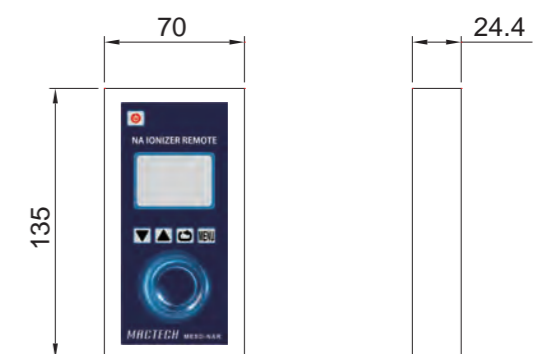

廣域高速型靜電消除器 Wide Range Ionizer

- 棒型  
Bar Type
- 區域型  
Area Type
- 扇型  
Fan Type
- 管型  
Tube Type
- 槍型  
Gun Type

- 棒型  
Bar Type
- 區域型  
Area Type
- 扇型  
Fan Type
- 管型  
Tube Type
- 槍型  
Gun Type

配件 Accessories

性能曲線圖 Static Elimination Performance

區域型標準配件  
Area Type Package Contents

▶ 區域型電纜線  
Power Cable (3 meter)  
MESD-CP027



▶ 中間固定架 Auxiliary Fixture  
MESD-BF601



耗材選購配件  
Consumable Options

▶ 無風式放電針  
Electrode Probe  
MESD-BP305



(使用壽命: 約8,000小時)  
(Life time: about 8,000 hrs)

▶ 延伸放電針 381mm  
Extended Electrode Probe  
MESD-BP304



▶ 延伸放電針 Extended Electrode Probe  
63.5/127/254/381/609/914/1524mm  
MESD-BP304-025/050/100/  
150/240/360/600



電源選購配件  
Power Supply Options

▶ 無風式電源供應器  
Power Supply(AC120V)  
MESD-CP060N



靜電消除區域與時間 Decay time

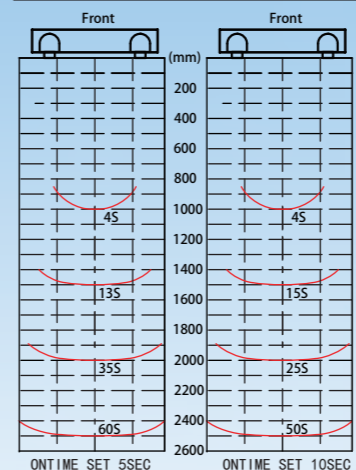

測試條件:  
· 電壓在±1000V到±100V範圍內的靜電消除時間  
· 使用150mm x 150mm (20pF) 平板測試儀  
· 下降氣流 0.3 m/s

Test Conditions:  
Ion static elimination time:  
From voltage ±1000V to ±100V  
Use 150mm x 150mm (20pF) CPM device  
Downdraft 0.3 m/s

上視有效範圍 Effective range

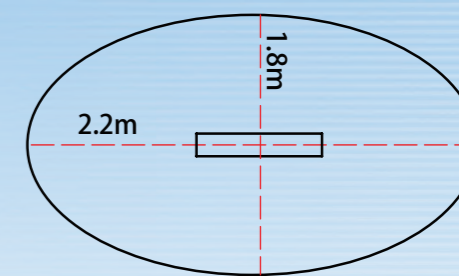

應用實例 Applications

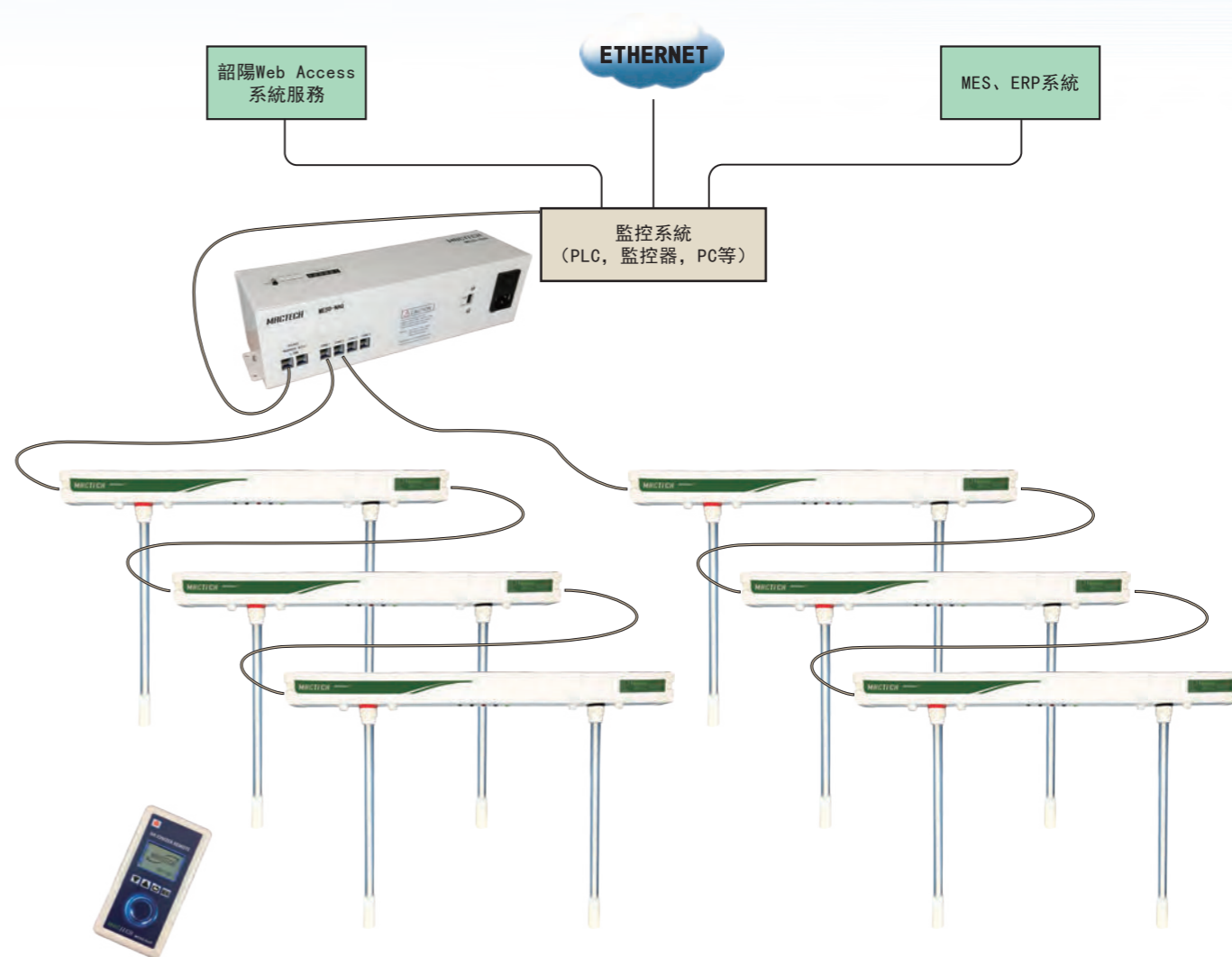



# 中域高速型靜電消除器 MESD-FA Medium Range Ionizer



▶ MESD-FA04  
離子平衡  
Ion Balance  $\pm 15V$

▶ MESD-FA05A  
離子平衡  
Ion Balance  $\pm 30V$

▶ MESD-FA05E  
離子平衡  
Ion Balance  $\pm 10V$



## 可變電壓直流模式 Variable DC Mode

在單電極針上分別施加正或負高壓，有效提升電離子生成量，實現高速靜電消除效果，與傳統AC相比可更有效提高離子生成。

Inflicting +/- voltage on the electrode probe individually, efficiently increasing the amount of ions generated, achieve high-speed static elimination, compared with the conventional AC mode generation can be more effectively improved.

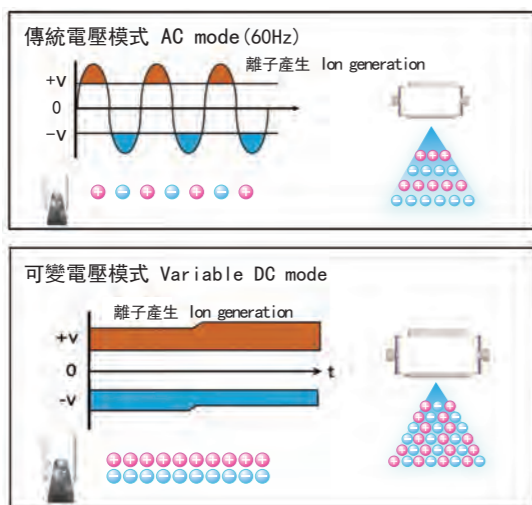

\*內部自我偵測，調整正負離子電壓水平  
\*Internal Self-detection, Adjust ion positive and negative balance.

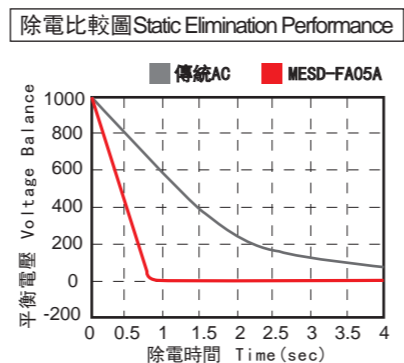

測試條件 距離 30cm  
±1000V到±100V消除靜電所需時間  
使用150mm x 150mm CPM (20pF)  
Test Conditions Distance 30cm  
Ion static elimination time: From voltage ±1000V to ±100  
Use 150mm x 150mm (20pF) CPM device

## 快速拔針機構設計 Quick Release Structure

簡易的換針方式，維護作業簡便、清潔輕鬆又便利。

Quick release electrode probe, make it easy to maintenance and clean up.

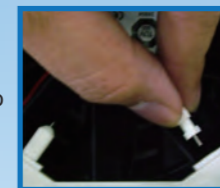

▶ MESD-FA04  
放電針Electrode Probe



▶ MESD-FA05A  
放電針Electrode Probe

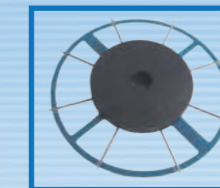

▶ MESD-FA05E  
放電針Electrode Probe

## 低電壓 DC24V Low Voltage

可有效避免放電所造成纜線老化與對週遭的裝置影響，建構高可靠性系統。  
Which can prevent cables gradually aging by the static discharge with high reliable system.

## 內建控制器 Control System

一體成型的設計，可有效節省安裝空間，輕鬆應付各種應用系統。  
All in one design model, save install space and suitable for any applications.

## 多功能顯示系統 Multi-function System

可顯示離子水平，離子平衡及風量調整。根據使用環境微調整，可提高靜電消除能力。  
Multi-function display system can display ion balance, adjustable fan volume and ion balance.  
Depending on the environment to adjust functions, improving the ability to eliminate static.

### 離子平衡顯示器 Ion Balance Status Display

長條型LED向+端亮起，代表產生的離子偏正離子居多；  
長條型LED向-端亮起，代表產生的離子偏負離子居多。

When lights close to +, It means + ion is more, when lights close to -, it means - ion is more.

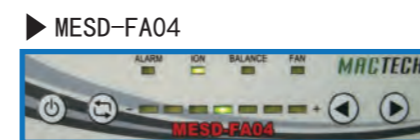

### 離子平衡設定顯示器 Ion Balance Setting Display

設定離子平衡。Ion balance setting.  
當長條型LED向+端亮起，代表產生離子偏正離子居多；  
當長條型LED向-端亮起，代表產生離子偏負離子居多。

When lights close to +, It means produce + ion is more, when lights close to -, it means produce - ion is more.



### 風量設定顯示器 Fan Volume Setting Display

設定風量大小。Fan Flow setting.  
當長條型LED向+端亮起，代表風量增加；  
當長條型LED向-端亮起，代表風量減少。

When lights close to +, it means fan speed is increased, when lights close to -, it means fan speed is decreased.

### 異常放電偵測/顯示 Abnormal Detection Display

當輸出電流異常的時候，系統會停止高壓輸出，以保護靜電消除器及使用者，並且亮起警示指示燈。

When output current is abnormal, system will stop high voltage output in order to protect user. Moreover alarm signal will be light up.

- 棒型  
Bar Type
- 區域型  
Area Type
- 扇型  
Fan Type
- 管型  
Tube Type
- 槍型  
Gun Type

## 規格 Specifications

產品型號 Model	MESD-FA04	MESD-FA05A	MESD-FA05E
輸入電源 Input Power	DC24V±5%		
消耗電流 Current Consumption	Approximate 600 mA	Approximate 970 mA	Approximate 970 mA
出力電源 Applied Voltage	±7KV (MAX)	±6.5KV (MAX)	±2.8KV (MAX)
離子平衡 Ion Balance	±15V *	±30V *	±10V *
建議設置距離 Operating Distance	150~1000 mm	100~1500 mm	50~1000 mm
介面顯示 LED Indicator	電源 Power Status: 電源入力時綠燈亮 When power input turns on green light 異常 Alarm Show: 紅燈亮 Red light on      數位顯示器呈現 Digital LED show "E" 功能 Function: 離子平衡、離子調整、風量顯示 Ion Balance, Ion Adjustment, Fan Volume      風量顯示 Fan Volume		
異常輸出接點 Power Safety Circuit	NPN電晶體出力 NPN Transistor output (Max. 50mA)		
臭氧量 Ozone Amount	0.03 ppm 以下 Under 0.03 ppm		
最大風速 Max Wind Speed	3.2 m/s *	4.3 m/s *	4.3 m/s *
風量 Air Flow	110 CFM	137 CFM	137 CFM
使用環境溫度 Ambient Temperature	15~40°C (室內 Indoor)		
使用環境溼度 Ambient Humidity	35~65% RH (無冷凝 No condensation)		

\* 量測條件 Measure Condition: 距離 Distance 300 mm

## 配件 Accessories

### 扇型標準配件 Fan Type Package Content

- ▶ 扇型電纜線 Power Cable (3 meter)  
MESD-CP023



### 耗材選購配件 Consumable Options

- ▶ 扇型放電針組 Electrode Probe (for MESD-FA04)  
MESD-EC04
- ▶ 扇型放電針組 Electrode Probe (for MESD-FA05A)  
MESD-EC05A
- ▶ 扇型放電針組 Electrode Probe (for MESD-FA05E)  
MESD-EC05E

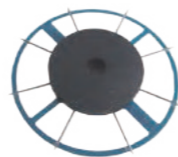

### 電源選購配件 Power Supply Options

- ▶ 扇型電源供應器 Power Supply 24W (for MESD-FA04)  
MESD-CP025J
- ▶ 扇型電源供應器 Power Supply 60W (for MESD-FA05A/E)  
MESD-CP060J



## 外觀尺寸 External Dimensions

單位 Unit: mm

### ▶ MESD-FA04

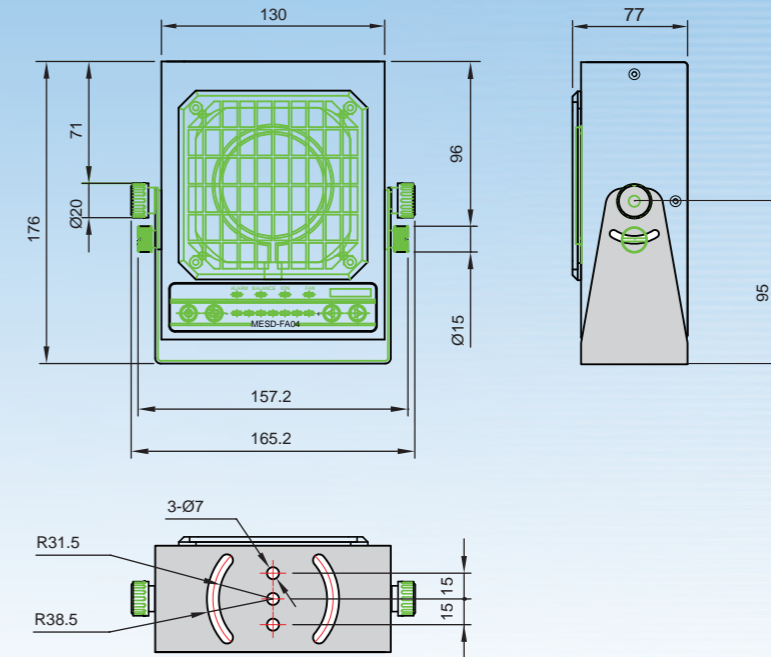

\* 有效區(出風口) Effective area: 90mm x 90mm

### ▶ MESD-FA05A & MESD-FA05E

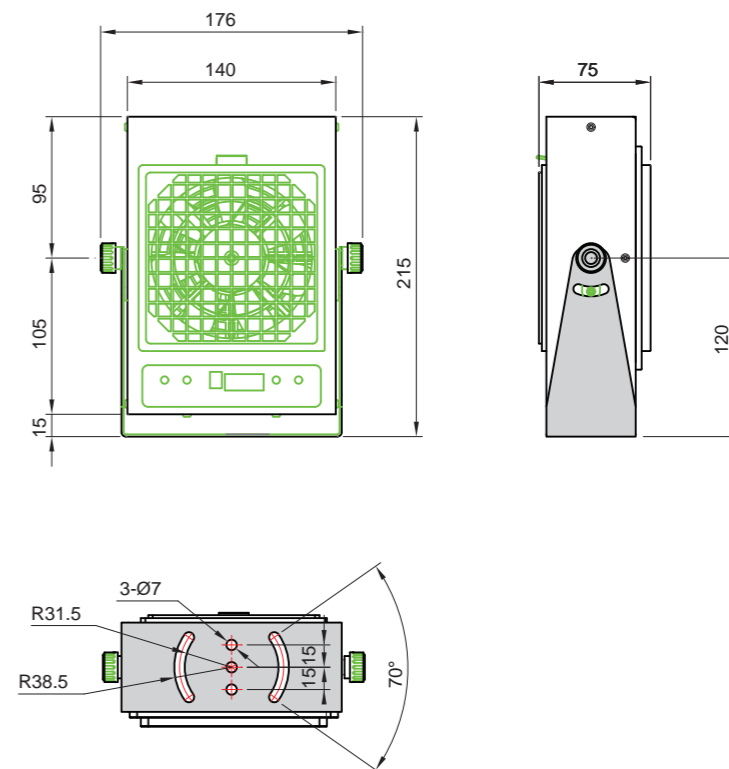

\* 有效區(出風口) Effective area: 110mm x 110mm

- 棒型  
Bar Type
- 區域型  
Area Type
- 扇型  
Fan Type
- 管型  
Tube Type
- 槍型  
Gun Type



- 棒型  
Bar Type
- 區域型  
Area Type
- 扇型  
Fan Type
- 管型  
Tube Type
- 槍型  
Gun Type

## 性能曲線圖 Static Elimination Performance

### ► MESD-FA04

除電區域與時間(最大風速) Decay Time(Max Speed)

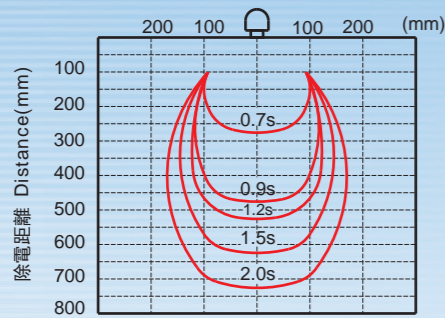

測試條件:  
 . 電壓在±1000V到±100V範圍內的靜電消除時間  
 . 使用150mm x 150mm (20pF) 平板測試儀  
 . 無下降氣流

Test Conditions:  
 Ion static elimination time:  
 From voltage ±1000V to ±100V  
 Use 150mm x 150mm (20pF) CPM device  
 No downdraft

除電與平衡能力 Static Elimination and Balance

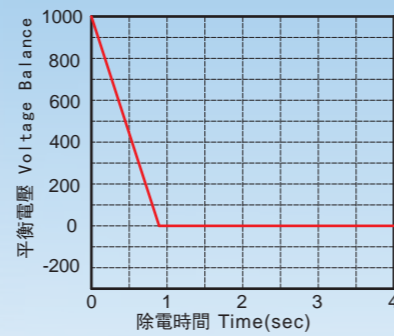

測試條件:  
 . 電壓在±1000V到±100V範圍內的靜電消除時間  
 . 使用150mm x 150mm (20pF) 平板測試儀  
 . 無下降氣流

Test Conditions:  
 Ion static elimination time:  
 From voltage ±1000V to ±100V  
 Use 150mm x 150mm (20pF) CPM device  
 No downdraft

風量與除電關係圖 Static Elimination Diagram

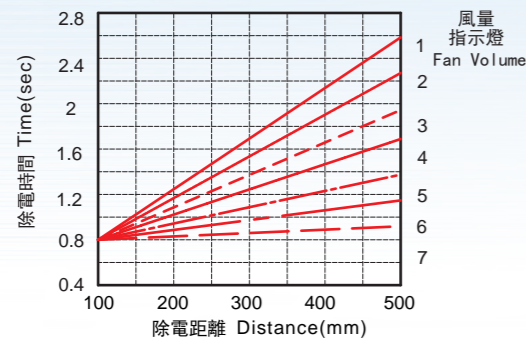

風速調整對應圖 Wind Speed Diagram

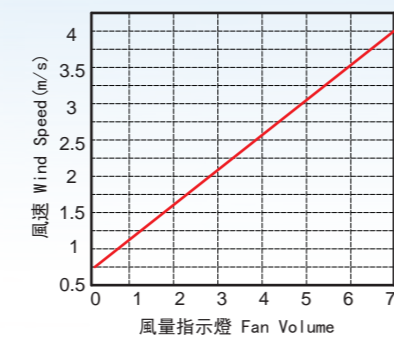

### ► MESD-FA05A

除電區域與時間(最大風速) Decay Time(Max Speed)

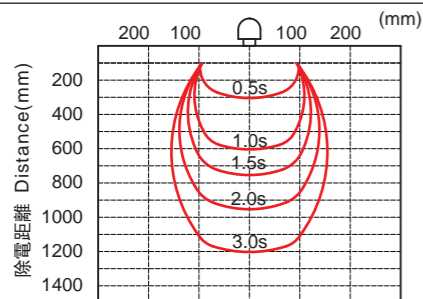

測試條件:  
 . 電壓在±1000V到±100V範圍內的靜電消除時間  
 . 使用150mm x 150mm (20pF) 平板測試儀  
 . 無下降氣流

Test Conditions:  
 Ion static elimination time:  
 From voltage ±1000V to ±100V  
 Use 150mm x 150mm (20pF) CPM device  
 No downdraft

### ► MESD-FA05E

除電區域與時間(最大風速) Decay Time(Max Speed)

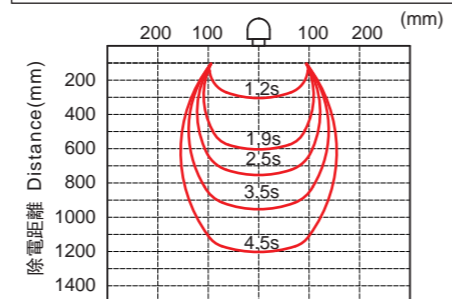

測試條件:  
 . 電壓在±1000V到±100V範圍內的靜電消除時間  
 . 使用150mm x 150mm (20pF) 平板測試儀  
 . 無下降氣流

Test Conditions:  
 Ion static elimination time:  
 From voltage ±1000V to ±100V  
 Use 150mm x 150mm (20pF) CPM device  
 No downdraft

### ► MESD-FA05A/E

風量與除電關係圖 Static Elimination Diagram

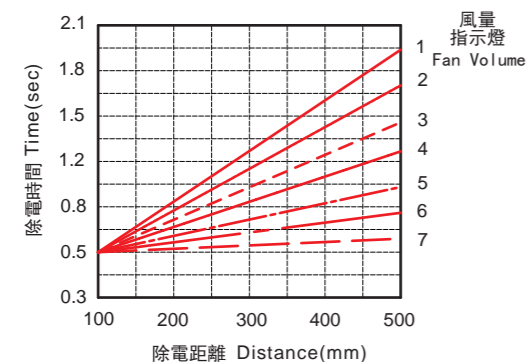

風速調整對應圖 Wind Speed Diagram

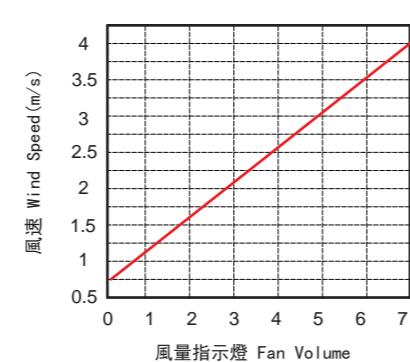

## 應用實例 Applications

- 棒型  
Bar Type
- 區域型  
Area Type
- 扇型  
Fan Type
- 管型  
Tube Type
- 槍型  
Gun Type

### ► 工作桌上產品消除靜電 In Workshop or on Working Tables

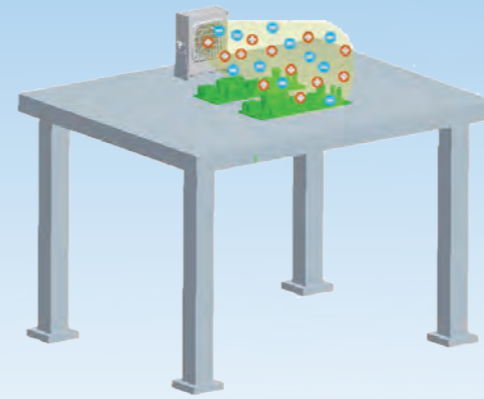

### ► 安裝於輸送帶機構 Conveyor Operation

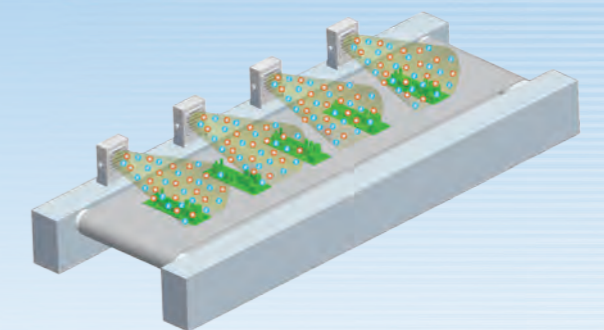

### ► 防止藥品充填附著異物 Container's Particle

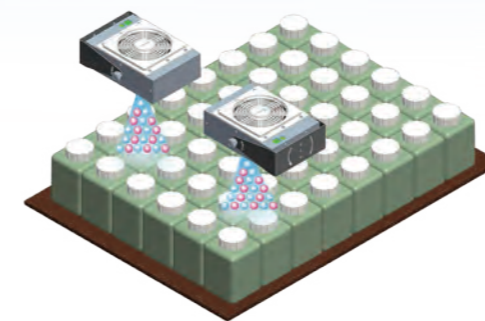

### ► 防止送料時髒污附著 Machine Feeding

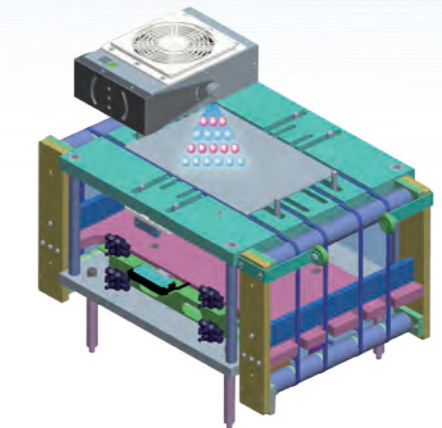

### ► 防止貼合時髒污附著 Lamination / Touch Panel

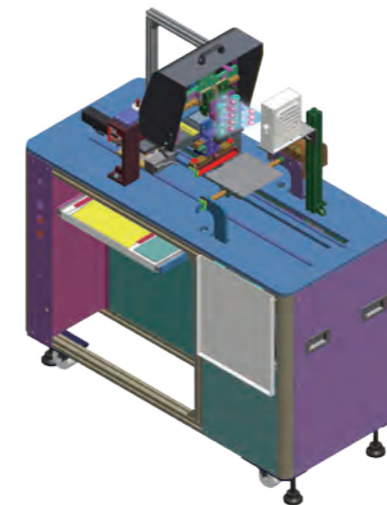

### ► 防止撕/貼膜時髒污附著 Peeling Films

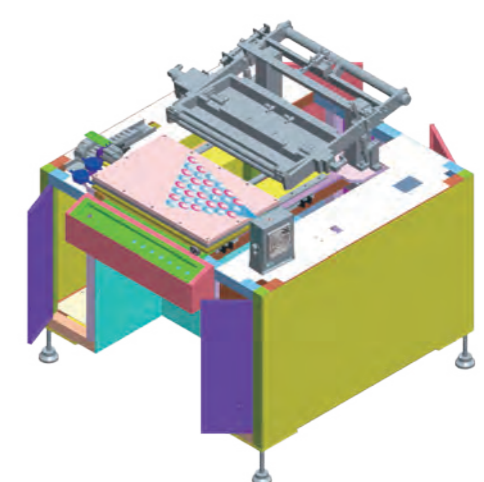



# 中域簡易型靜電消除器 MESD-FA Medium Range Ionizer

棒型  
Bar Type

區域型  
Area Type

扇型  
Fan Type

管型  
Tube Type

槍型  
Gun Type



## 規格 Specifications

產品型號 Model	MESD-FA05C1 /2	MESD-FA02C1 /2
輸入電源 Input Power	AC 110V / 220V	AC 110V / 220V
消耗電流 Current Consumption	Approximate 0.25A / 0.12A	Approximate 0.9A / 0.45A
出力電源 Applied Voltage	AC ±6KV (MAX)	
離子平衡 Ion Balance	±20V *	
建議設置距離 Operating Distance	100~500 mm	
電源指示燈 Power Status	電源入力時綠燈亮 When power input turns on green light	
最大風速 Max Wind Speed	1.8 m/s (300 mm)	
風量 Air Flow	45~110 CFM	
噪音值 Noise Value	65dB (MAX)	
臭氧量 Ozone Amount	<0.03 ppm	
使用環境溫度 Ambient Temperature	15~40°C (室內 Indoor)	
使用環境溼度 Ambient Humidity	35~65% RH (無冷凝 No condensation)	

\* 量測條件 Measure Condition: 距離 Distance 300mm

棒型  
Bar Type

區域型  
Area Type

扇型  
Fan Type

管型  
Tube Type

槍型  
Gun Type



▶ MESD-FA05C

離子平衡  
Ion Balance ±20V

▶ MESD-FA02C

離子平衡  
Ion Balance ±20V

## 快速清針機構設計 Quick Clean Structure

簡易的清針方式，維護作業簡便、清潔輕鬆又便利。  
The structure is designed for simple maintenance to clean the electrode probe more easily.

## 隨插即用操作簡單 Plug and Use

使用110V / 220V AC電源，無須轉換電壓，隨插即用；只需調整風量，無細部調整問題。  
Plug the power cord 110V or 220V AC Volts into the Ionizer, after that please adjust the air volume and it works without the further adjustment.

## 產品特色 Features

- 高精度、適用範圍廣泛。 The Ionizer with high precision can be used to various applications.
- 低噪音、靜音機構設計。 Achieve low noise feature.
- 無段速控制，輕鬆調整風量。 Adjust the air volume easily.
- 簡易操作設計，使用更方便。 Simple operation makes it easy to use.
- 快速清針機構，省時省成本。 Easy to clean the electrode probe, to reduce the cost and save time.

## 外觀尺寸 External Dimensions

單位 Unit: mm

▶ MESD-FA05C

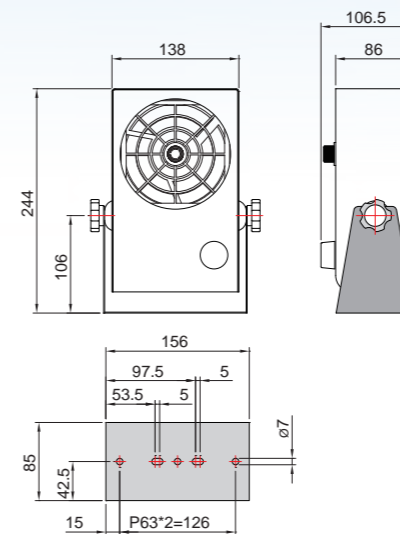

▶ MESD-FA02C

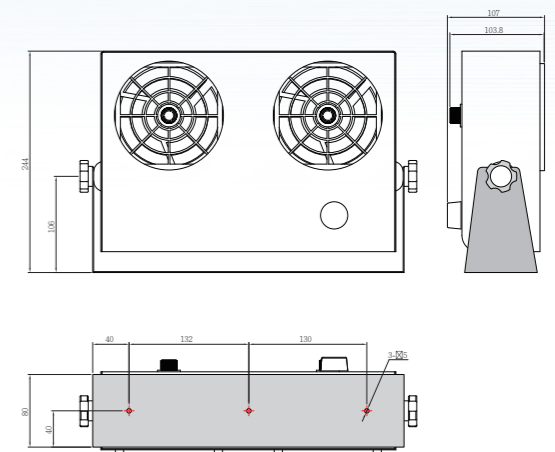

\* 有效區(出風口) Effective area:  $\phi 120\text{mm}$

## 性能曲線圖 Static Elimination Performance

除電區域與時間(最大風速) Decay Time(Max Speed)

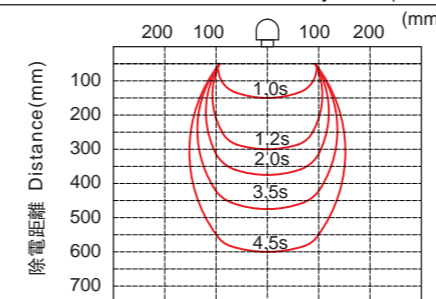

測試條件:  
· 電壓在±1000V到±100V範圍內的靜電消除時間  
· 使用150mm x 150mm (20pF) 平板測試儀  
· 無下降氣流

Test Conditions:  
Ion static elimination time:  
From voltage ±1000V to ±100V  
Use 150mm x 150mm (20pF) CPM device  
No downdraft

風速調整對應圖 Wind Speed Diagram

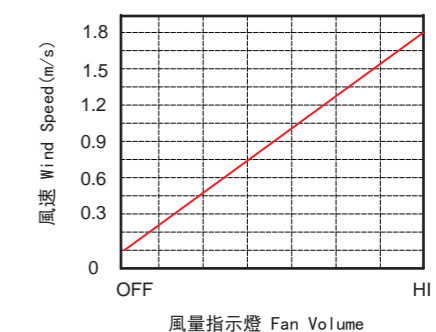



# 窄域定點型靜電消除器 MESD-HA Narrow Range Ionizer

- 棒型  
Bar Type
- 區域型  
Area Type
- 扇型  
Fan Type
- 管型  
Tube Type
- 槍型  
Gun Type

- 棒型  
Bar Type
- 區域型  
Area Type
- 扇型  
Fan Type
- 管型  
Tube Type
- 槍型  
Gun Type

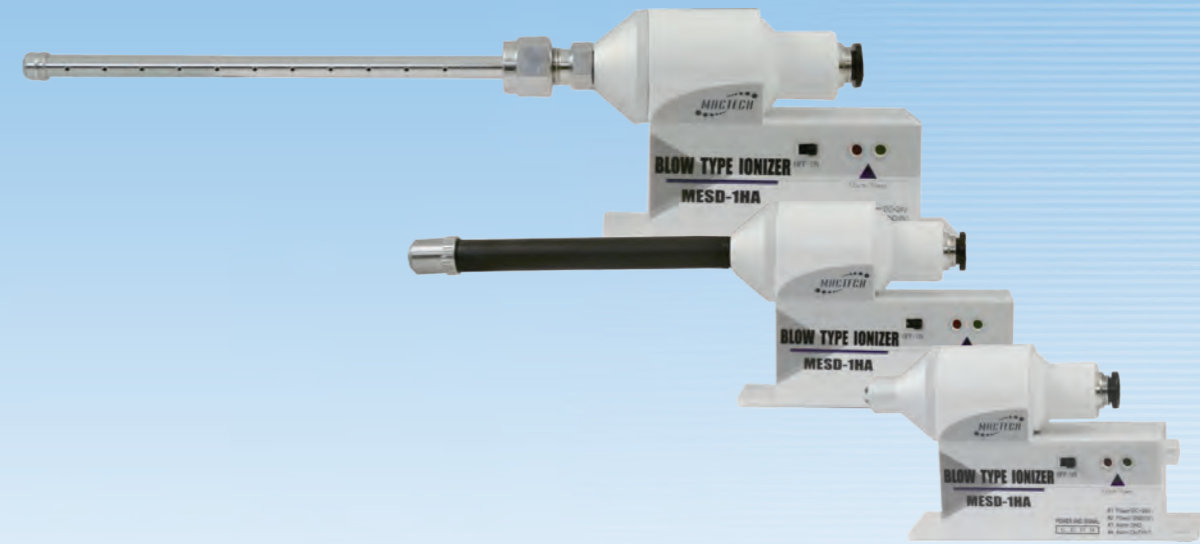

▶ MESD-1HA

▶ MESD-2HA

## 高頻電壓AC模式 High Frequency AC Mode

放電針正負快速交替，可以有效的產生大量正負離子，加快消除靜電能力。  
Electrode probe rapidly interflow, can effectively produce large of positive and negative ions, accelerate the elimination of capacity.

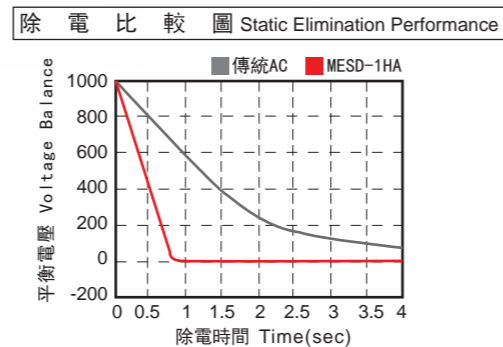
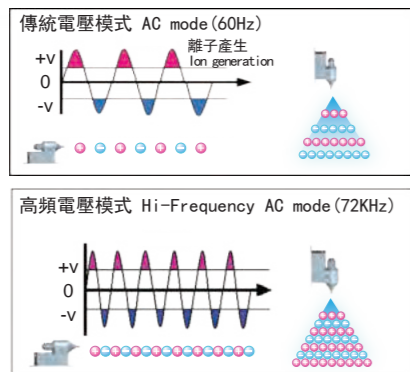

測試條件 距離 30cm Test Conditions Distance 30cm  
±1000V到±100V消除靜電所需時間 Elimination time : From ±1000V to ±100V  
使用150mm x 150mm CPM (20pF) Use 150mm x 150mm (20pF) CPM device

## 高精度低平衡電壓 High Precision Voltage Balance

利用高頻電壓模式，可有效提高離子平衡度到±15V。  
Using high voltage mode, can boost ions balance up to ±15V.

距離與離子平衡關係圖 Distance and Ion Balance Diagram

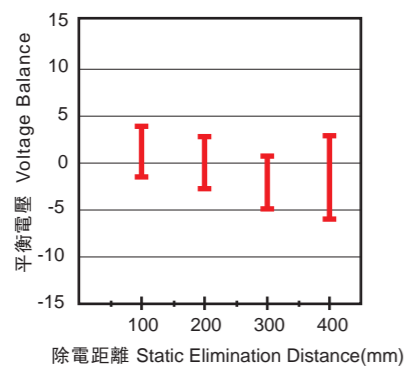

離子平衡電壓圖 Ion Balance and Voltage Diagram

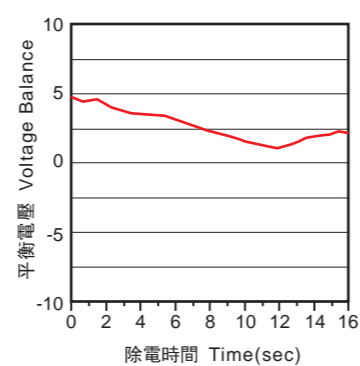

## 產品特色 Features

### 檢視系統 Inspection System

內建LED顯示，綠燈亮起時表示電源入力正常，紅燈亮時表示異常輸出，以提供快速檢視系統狀態。  
When green light turns on, it means output normal. When red light turns on, it means output alarm. To provide inspecting status of system rapidly.



### 低電壓DC24V輸入 Input of DC24V Low Voltage

可有效避免放電所造成纜線老化與對週遭的裝置影響，建構高可靠性系統。  
Which can prevent cables gradually aging by the static discharge with high reliable system.

### 內建高壓電源系統 Mounted High Voltage System

無需使用專用高壓配線，無高壓配線困擾，並且可有效節省安裝空間，由於外觀尺寸很小，方便裝置於狹小空間，輕鬆應付各種系統安裝之需求。  
Without using a high-voltage cable, moreover can effectively save installation space. Due to the appearance of small size, convenient for small space, easy to cope with the demand of various system installation.

- 棒型  
Bar Type
- 區域型  
Area Type
- 扇型  
Fan Type
- 管型  
Tube Type
- 槍型  
Gun Type

### 功能解析 Functions Explanation



多樣式噴嘴，適用多種場合  
Different nozzles, using in various industry



簡易顯示，快速判別狀態  
Clear display status, easy to determine



快拆放電針組，保養容易  
Quick-release electrode probe, easy to maintain

高精度離子平衡可達 ±15V  
High Precision Ion Balance up to ±15V

體積小，適合空間狹小場合  
Small device, easy to installation

### 外觀尺寸 External Dimensions

單位 Unit: mm

#### ► MESD-1HA

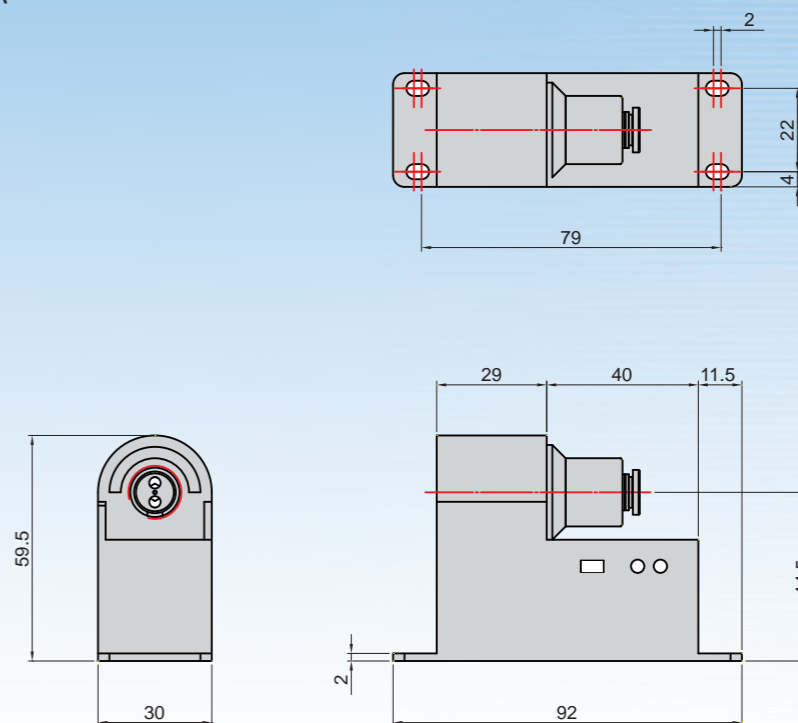

#### ► MESD-2HA

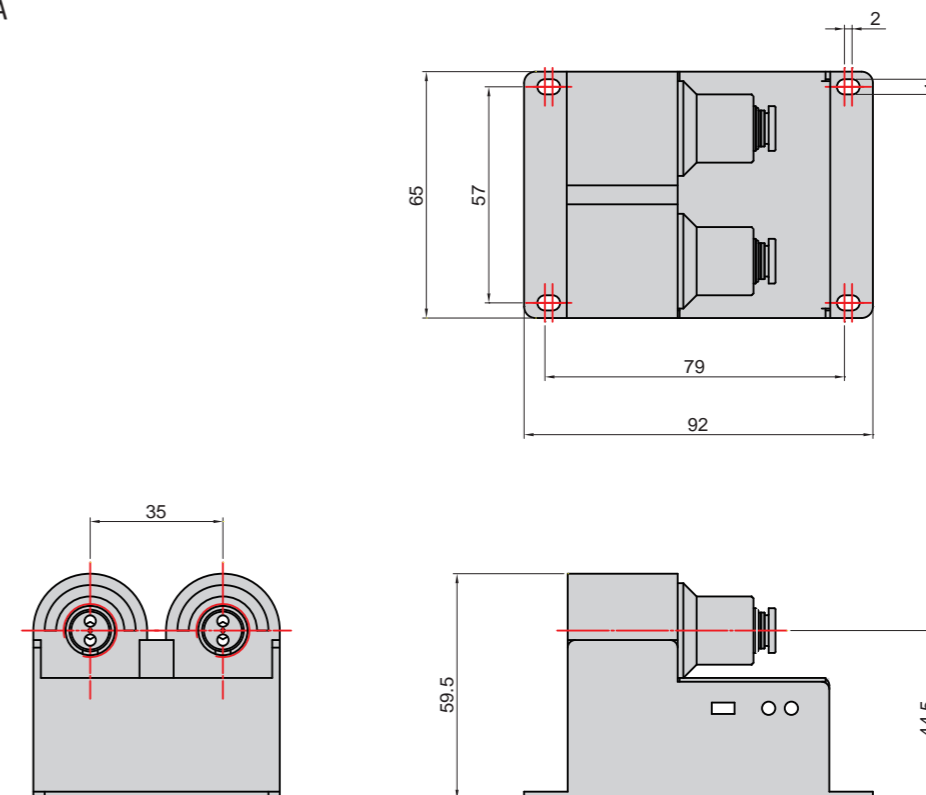

### 規格 Specifications

產品型號 Model	MESD-1HA	MESD-2HA
使用流體 Air Flow	乾燥壓縮空氣 Compressed Dry Air	
輸入電源 Input Power	DC 24V ±5%	
消耗電流 Current Consumption	Approximate 100 mA	Approximate 200 mA
出力電源 Applied Voltage	±2.2KV 72 KHz (MAX)	
離子平衡 Ion Balance	±15V (距離 Distance 300 mm)	
建議設置距離 Operating Distance	50~500 mm	
動作指示燈 LED Indicator	電源 Power Status	電源入力時綠燈亮 When power input LED turn on green light
	異常 Alarm Show	異常時紅燈亮 When abnormal LED turn on red light
異常輸出接點 Power Safety Circuit	NPN電晶體出力 NPN Transistor output (Max. 24mA)	
臭氧量 Ozone Amount	0.03 ppm 以下 Under 0.03 ppm	
最大空氣流量 Max CDA Consumption	Approximate 60 ℓ/min	Approximate 120 ℓ/min
使用壓力範圍 Air Pressure Range	0.01~0.5 MPa	
使用環境溫度 Ambient Temperature	15~40°C (室內 Indoor)	
使用環境溼度 Ambient Humidity	35~65% RH (無冷凝 No condensation)	



- 棒型  
Bar Type
- 區域型  
Area Type
- 扇型  
Fan Type
- 管型  
Tube Type
- 槍型  
Gun Type

## 配件 Accessories

### 管型標準配件 Tube Type Package Content

- ▶ 管型電纜線 Power Cable (2 meter)  
MESD-CP024



### 噴嘴選購配件 Nozzle Accessory Options

- ▶ 可撓管型噴嘴組 Flexible Tube Nozzle  
MESD-F100L~F500L



- ▶ 標準型噴嘴組 Standard Nozzle  
MESD-NSTA



- ▶ 120° 擴散型噴嘴組 Spread Nozzle  
MESD-N120A



### 耗材選購配件 Consumable Options

- ▶ 管型放電針組 Electrode Probe  
MESD-HA303



(使用壽命：約6,000小時)  
(Life time: about 6,000 hrs)

- ▶ 棒型不鏽鋼管噴嘴組 Stainless Steel Pipe Nozzle  
MESD-S100L~S500L



- ▶ 90° 擴散型噴嘴組 Spread Nozzle  
MESD-N90CA



- ▶ 90° 平式擴散型噴嘴組 Horizontal Spread Nozzle  
MESD-N90L



### 電源選購配件 Power Supply Options

- ▶ 管型電源供應器 Power Supply 24W  
MESD-CP025C



單位 Unit: mm

- ▶ 可撓管型噴嘴組 Flexible Tube Nozzle  
MESD-F100L~F500L

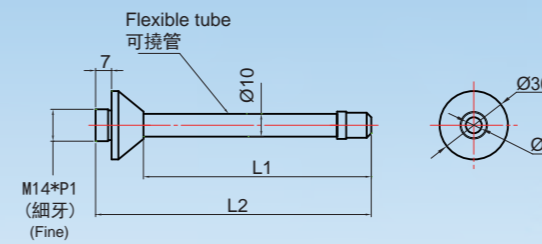

型號 Model	L1	L2
MESD-F100L	100	121
MESD-F200L	200	221
MESD-F300L	300	321
MESD-F400L	400	421
MESD-F500L	500	521

\* 超過300L為訂單生產，建議選購BC系列  
The length of tube over 300mm is make-to-order;  
we recommend choosing BC series.

- ▶ 標準型噴嘴組 Standard Nozzle  
MESD-NSTA

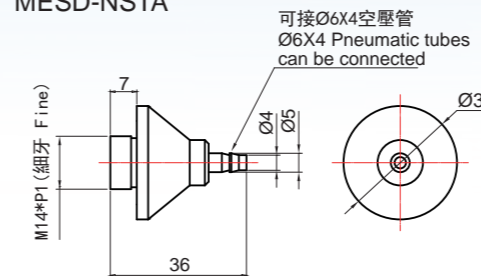

- ▶ 120° 擴散型噴嘴組 Spread Nozzle  
MESD-N120A

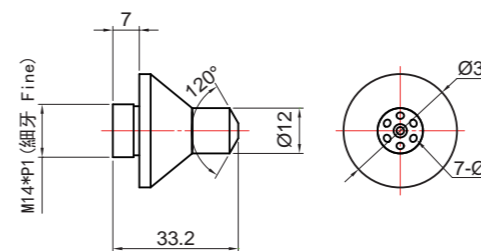

- ▶ 鋼管噴嘴固定架 Stainless Steel Pipe Fixture  
MESD-BA01

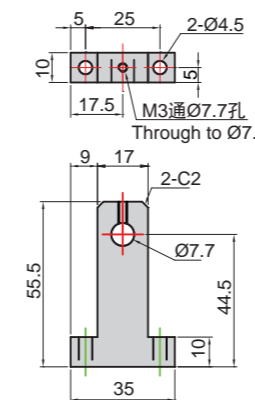

- ▶ 棒型不鏽鋼管噴嘴組 Stainless Steel Pipe Nozzle  
MESD-S100L~S700L

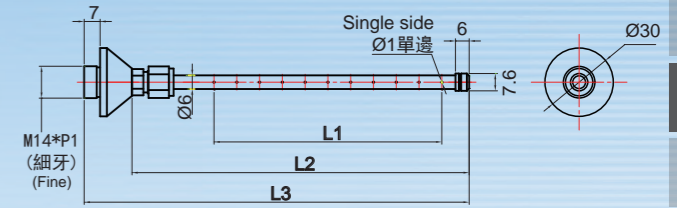

型號 Model	孔數 No. of hole	L1	L2	L3
MESD-S100L	10	100	148	169
MESD-S200L	20	200	248	269
MESD-S300L	30	300	348	369
MESD-S400L	40	400	448	469
MESD-S500L	50	500	548	569
MESD-S600L	60	600	648	669
MESD-S700L	70	700	748	769

\* 超過300L為訂單生產，建議選購BC系列  
The length of tube over 300mm is make-to-order;  
we recommend choosing BC series.

- ▶ 90° 擴散型噴嘴組 Spread Nozzle  
MESD-N90CA

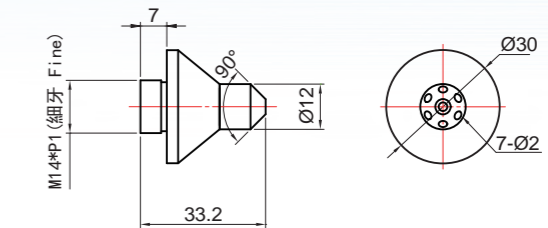

- ▶ 90° 平式擴散型噴嘴組 Horizontal Spread Nozzle  
MESD-N90L

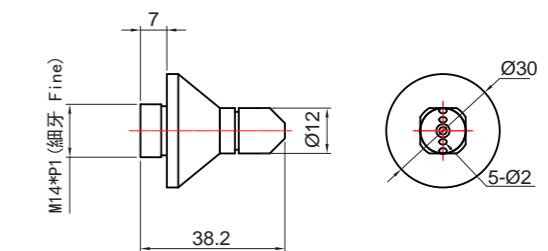

- ▶ 萬向軟管噴嘴 Adjustable Hoses Nozzle  
MESD-NSH

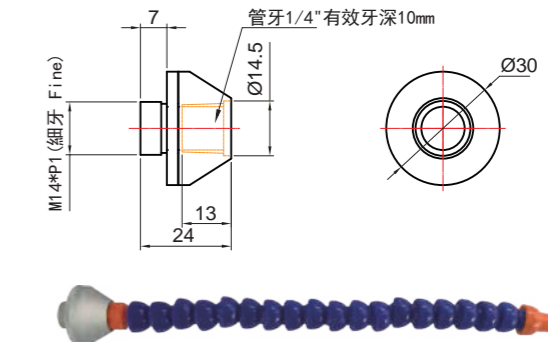

窄域定點型靜電消除器 Narrow Range Ionizer

# 窄域定點型靜電消除器 MESD-HB Narrow Range Ionizer

- 棒型  
Bar Type
- 區域型  
Area Type
- 扇型  
Fan Type
- 管型  
Tube Type
- 槍型  
Gun Type

機械手臂產線適用  
Suitable for Robotic Arm



## 體積小效能高 Small Size and High Efficiency

高度壓縮僅22mm，可安裝於狹小空間  
The height is only 22mm, which can be installed in small space.

## 安裝簡易好設定 Easy to Install and Set Up

安裝只需二根螺絲，設定只需調整風量  
Using two screws to install the product and only need to adjust air volume for setting.

## 規格 Specifications

項目 Items	規格 Specifications
使用流體 Air Flow	乾燥壓縮空氣 Compressed Dry Air
輸入電源 Input Power	DC 24V ±5%
消耗電流 Current Consumption	Approximate 100 mA
出力電源 Applied Voltage	±2.2KV 90 KHz (MAX)
離子平衡 Ion Balance	±15V (距離 Distance 300 mm)
建議設置距離 Operating Distance	50~500 mm
動作指示燈 LED Indicator	電源輸入時綠燈亮 When power input LED turn on green light 異常時紅燈亮 When abnormal LED turn on red light
異常輸出接點 Power Safety Circuit	NPN電晶體輸出 NPN Transistor output (Max. 24 mA)
臭氧量 Ozone Amount	0.03 ppm 以下 Under 0.03 ppm
最大空氣流量 Max CDA Consumption	Approximate 60 l/min
使用壓力範圍 Air Pressure Range	0.05~0.5 MPa
使用環境溫度 Ambient Temperature	15~40°C (室內 Indoor)
使用環境溼度 Ambient Humidity	35~65% RH (無冷凝 No condensation)

- 棒型  
Bar Type
- 區域型  
Area Type
- 扇型  
Fan Type
- 管型  
Tube Type
- 槍型  
Gun Type

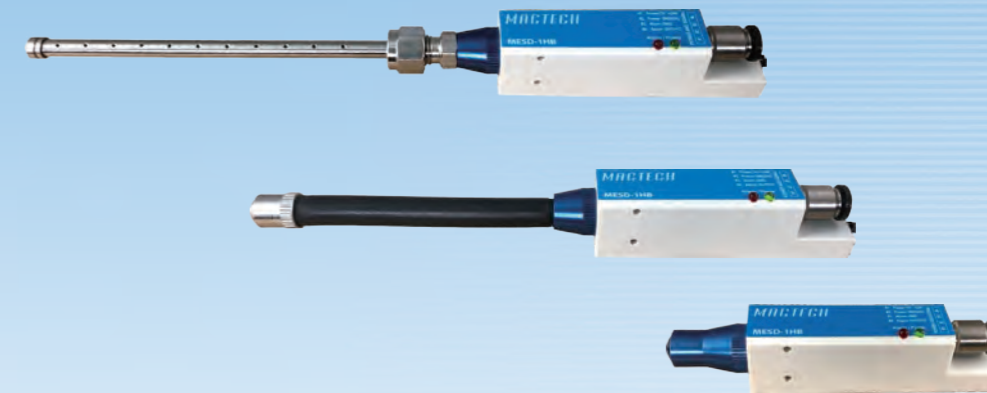

\*提供多樣噴嘴頭以適用於不同產業\*  
\*Provide different nozzles • Using in various industry\*

## 外觀尺寸 External Dimensions

單位 Unit: mm

### ► MESD-1HB

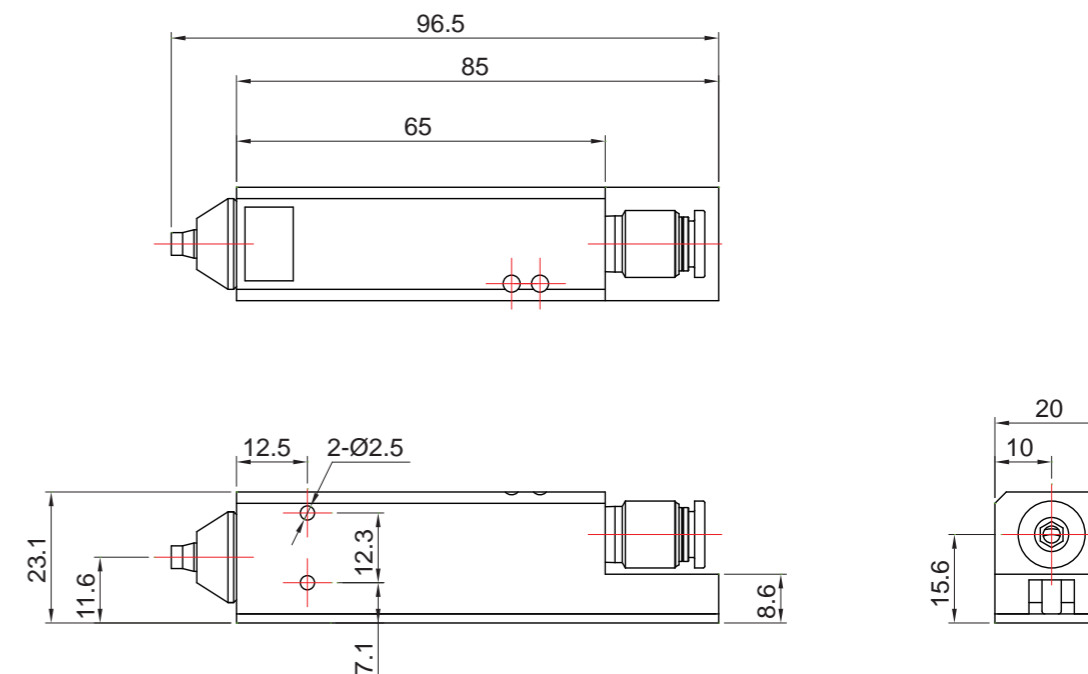



- 棒型  
Bar Type
- 區域型  
Area Type
- 扇型  
Fan Type
- 管型  
Tube Type
- 槍型  
Gun Type

配件 Accessories

管型標準配件  
Tube Type Package Content

- ▶ 管型電纜線 Power Cable (2 meter)  
MESD-CP024



噴嘴選購配件  
Nozzle Accessory Options

- ▶ 可撓管型噴嘴組 Flexible Tube Nozzle  
MESD-F100LB~F500LB



- ▶ 棒型不鏽鋼管噴嘴組 Stainless Steel Pipe Nozzle  
MESD-S100LB~S500LB



- ▶ 標準型噴嘴組 Standard Nozzle  
MESD-NSTB



- ▶ 120° 擴散型噴嘴組 Spread Nozzle  
MESD-N120B



- ▶ 90° 擴散型噴嘴組 Spread Nozzle  
MESD-N90CB



- ▶ 90° 平式擴散型噴嘴組 Horizontal Spread Nozzle  
MESD-N90LB



電源選購配件  
Power Supply Options

- ▶ 管型電源供應器 Power Supply 24W  
MESD-CP025B



單位 Unit: mm

- ▶ 可撓管型噴嘴組 Flexible Tube Nozzle  
MESD-F100LB~F500LB

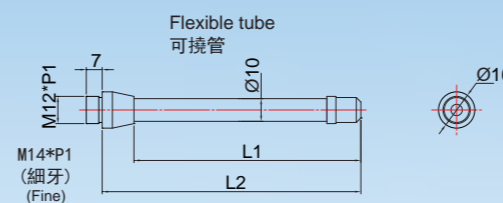

型號 Model	L1	L2
MESD-F100LB	100	114
MESD-F200LB	200	214
MESD-F300LB	300	314
MESD-F400LB	400	414
MESD-F500LB	500	514

\* 超過300LB為訂單生產，建議選購BC系列  
The length of tube over 300mm is make-to-order;  
we recommend choosing BC series.

- ▶ 棒型不鏽鋼管噴嘴組 Stainless Steel Pipe Nozzle  
MESD-S100LB~S700LB

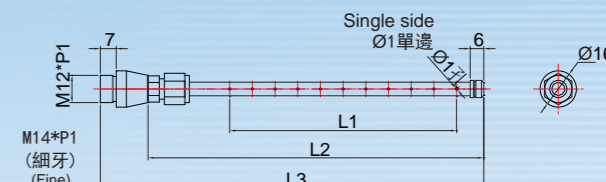

型號 Model	孔數 No. of hole	L1	L2	L3
MESD-S100LB	10	100	148	169
MESD-S200LB	20	200	248	269
MESD-S300LB	30	300	348	369
MESD-S400LB	40	400	448	469
MESD-S500LB	50	500	548	569
MESD-S600LB	60	600	648	669
MESD-S700LB	70	700	748	769

\* 超過300LB為訂單生產，建議選購BC系列  
The length of tube over 300mm is make-to-order;  
we recommend choosing BC series.

- ▶ 標準型噴嘴組 Standard Nozzle  
MESD-NSTB

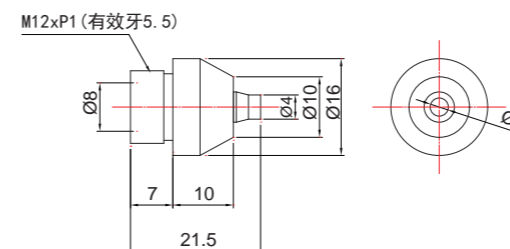

- ▶ 120° 擴散型噴嘴組 Spread Nozzle  
MESD-N120B

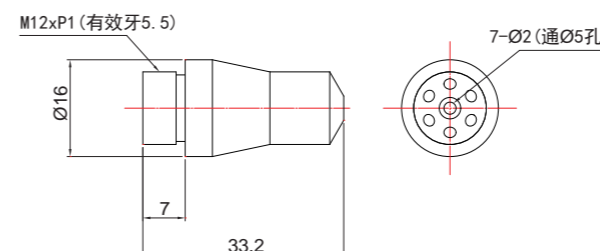

- ▶ 90° 擴散型噴嘴組 Spread Nozzle  
MESD-N90CB

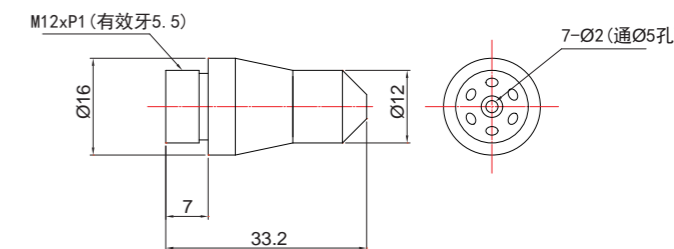

- ▶ 90° 平式擴散型噴嘴組 Horizontal Spread Nozzle  
MESD-N90LB

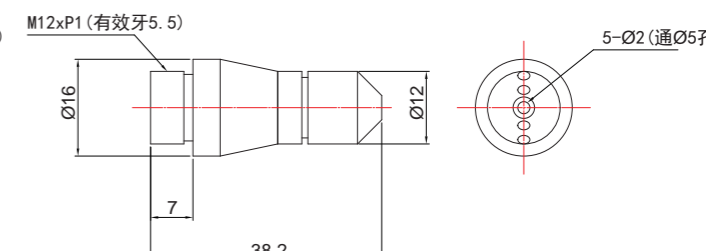

- 棒型  
Bar Type
- 區域型  
Area Type
- 扇型  
Fan Type
- 管型  
Tube Type
- 槍型  
Gun Type

性能曲線圖 *Static Elimination Performance*

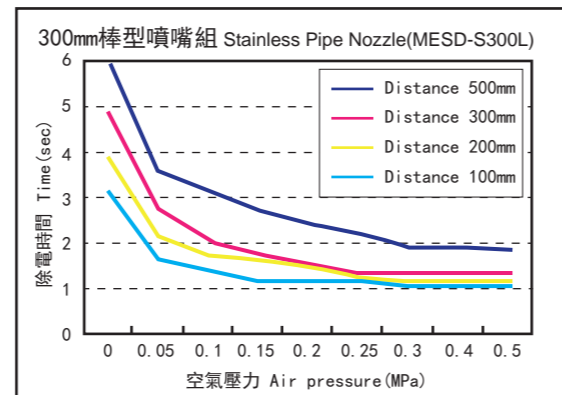
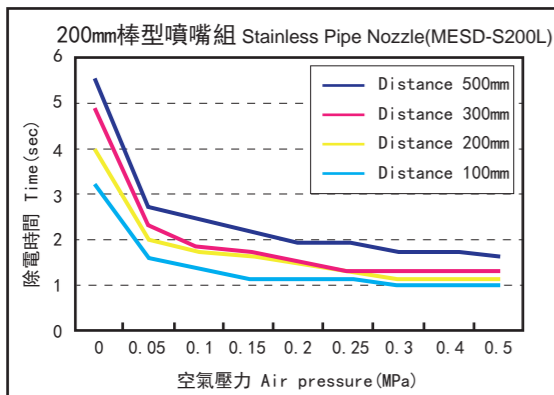
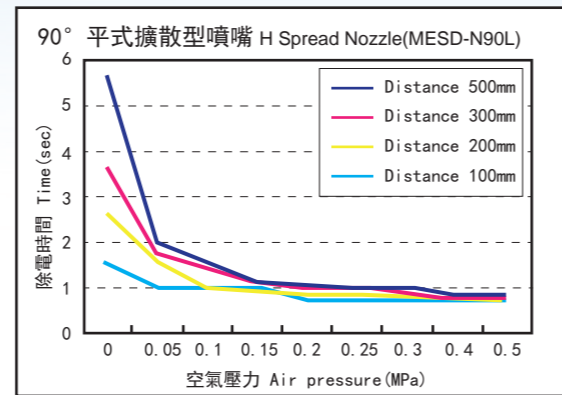
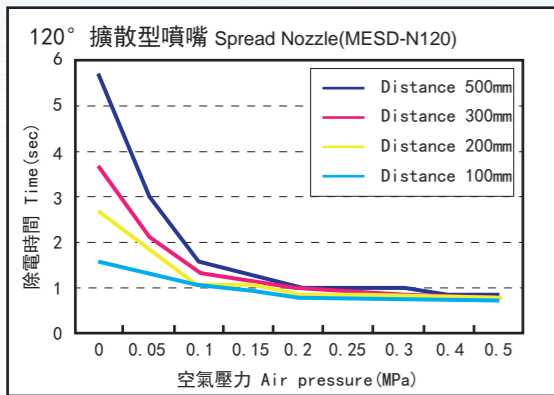
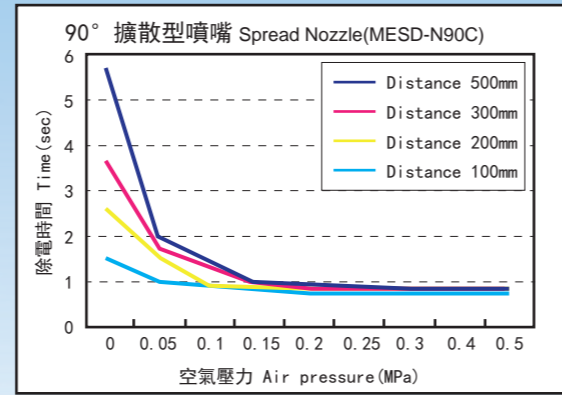
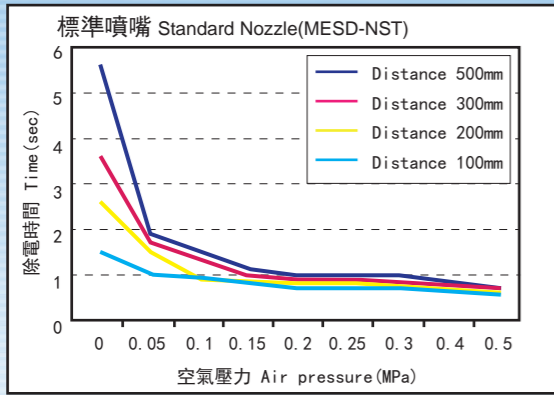

應用實例 *Applications*

- 棒型  
Bar Type
- 區域型  
Area Type
- 扇型  
Fan Type
- 管型  
Tube Type
- 槍型  
Gun Type

► 應用於滾輪輸送機構  
Conveyor Production Processes

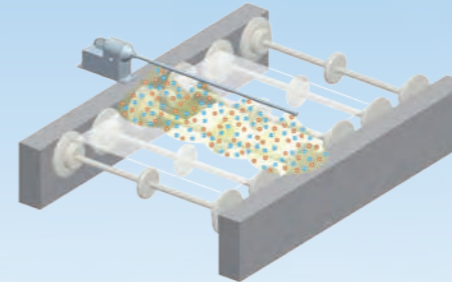

► 滾輪摩擦靜電消除  
Rewinding Machines

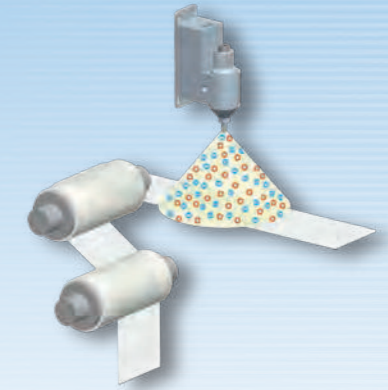

► 撕/貼膜機靜電消除  
Peeling Films & Lamination

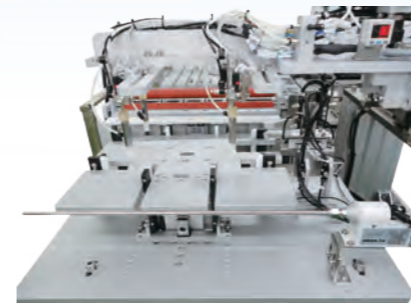

► 捲料機構靜電消除  
Operation Machines

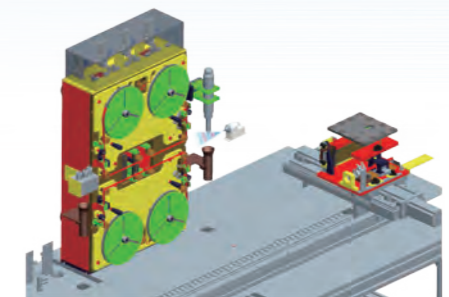

► 機械手臂搬運靜電消除  
Robot Transferred

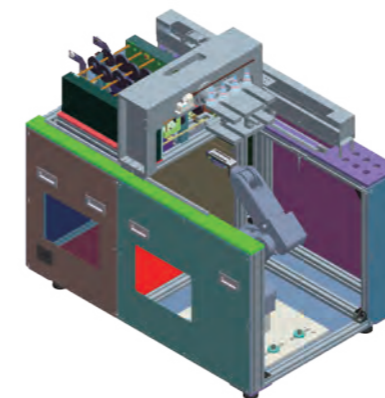

► 應用於玻璃切割時的靜電消除  
Glass Cutting Machines

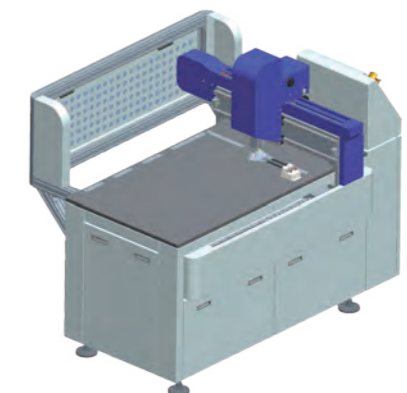



# 窄域定點型靜電消除器 MESD-GA Narrow Range Ionizer

- 棒型  
Bar Type
- 區域型  
Area Type
- 扇型  
Fan Type
- 管型  
Tube Type
- 槍型  
Gun Type



## 高頻電壓AC模式 High Frequency AC Mode

放電針正負快速交替，可以有效的產生大量正負離子，加快消除靜電能力。  
Electrode probe rapidly interflow, can effectively produce large of positive and negative ions, accelerate the elimination of capacity.

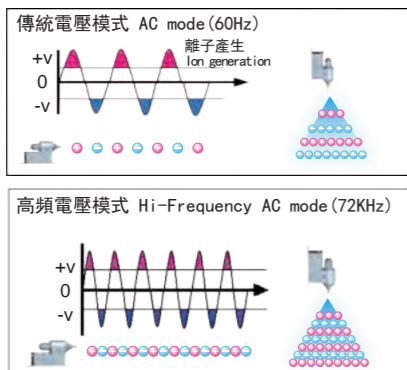

除電比較圖 Static Elimination Performance

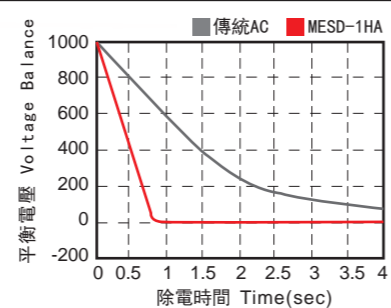

測試條件 距離 30cm Test Conditions Distance 30cm  
±1000V到±100V消除靜電所需時間 Elimination time : From ±1000V to ±100V  
使用150mm x 150mm CPM (20pF) Use 150mm x 150mm (20pF) CPM device

## 高精度低平衡電壓 High Precision Voltage Balance

利用高頻電壓模式，可有效提高離子平衡度到±15V。  
Using high voltage mode, can boost ions balance up to ±15V.

距離與離子平衡關係圖 Distance and Ion Balance Diagram

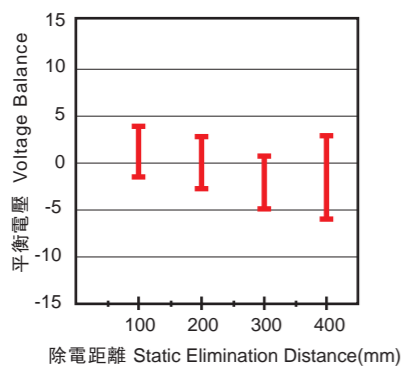

離子平衡電壓圖 Ion Balance and Voltage Diagram

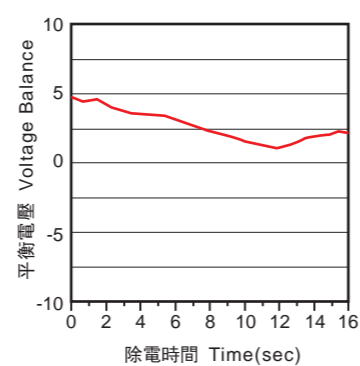

- 棒型  
Bar Type
- 區域型  
Area Type
- 扇型  
Fan Type
- 管型  
Tube Type
- 槍型  
Gun Type



## 人體工學設計 Ergonomic Design

加強握把輕羽量設計，  
有效提升產品使用舒適度與便利性。  
Strengthen handle light feather design,  
effectively enhance product comfort and convenience.

## 防滑與快勾設計 Slip-proof and Hook Design

1. 皮革紋路流線造型，有效提升防滑效果與手握觸感。  
Leather texture streamlined shape, effectively enhance the slip-proof effect and hand touch.
2. 快速掛勾設計好收取。  
A hook design is good to take and keep.



## 產品特色 Features

### 顯示系統 Alarm System

內建LED顯示，綠燈亮起時表示電源入力正常，紅燈亮時表示異常輸出，  
以提供快速監視系統狀態。  
When green light truns on, it means output normal. When red light truns on,  
it means output alarm. To provide monitoring status of system rapidly.



### 低電壓 DC24V 輸入 Input of DC24V Low Voltage

可有效避免放電所造成纜線老化與對週遭的裝置影響，建構高可靠性系統。  
Which can prevent cables gradually aging by the static discharge with high reliable system.

### 一體成型設計 All In One Design

無需使用專用高壓配線，無高壓配線困擾，並且可有效節省安裝空間。由於外觀尺寸很小，  
方便裝置於狹小空間，輕鬆應付各種系統安裝之需求。  
Without the use of special high-voltage wiring, no high-voltage wiring problems, and can effectively save  
installation space. Due to the external a small size, therefore it is convenient to install in a small space,  
and easy to meet the needs of the various systems installation requirement.

- 棒型  
Bar Type
- 區域型  
Area Type
- 扇型  
Fan Type
- 管型  
Tube Type
- 槍型  
Gun Type**

## 規格 Specifications

項目 Items	規格 Specifications				
使用流體 Air Flow	乾燥壓縮空氣 Compressed Dry Air				
輸入電源 Input Power	DC 24V ±5%				
消耗電流 Current Consumption	Approximate 100 mA				
出力電源 Applied Voltage	±2.2KV 72 KHz (MAX)				
離子平衡 Ion Balance	±15V (距離 Distance 300 mm)				
建議設置距離 Operating Distance	50~500 mm				
動作指示燈 LED Indicator	<table border="0"> <tr> <td>電源 Power Status</td> <td>電源入力時綠燈亮 When power input LED turn on green light</td> </tr> <tr> <td>異常 Alarm Show</td> <td>異常時紅燈亮 When abnormal LED turn on red light</td> </tr> </table>	電源 Power Status	電源入力時綠燈亮 When power input LED turn on green light	異常 Alarm Show	異常時紅燈亮 When abnormal LED turn on red light
電源 Power Status	電源入力時綠燈亮 When power input LED turn on green light				
異常 Alarm Show	異常時紅燈亮 When abnormal LED turn on red light				
異常輸出接點 Power Safety Circuit	NPN電晶體出力 NPN Transistor output (Max. 24 mA)				
臭氧量 Ozone Amount	0.03 ppm 以下 Under 0.03 ppm				
最大空氣流量 Max CDA Consumption	Approximate 60 l/min				
使用壓力範圍 Air Pressure Range	0.01~0.5 MPa				
使用環境溫度 Ambient Temperature	15~40°C (室內 Indoor)				
使用環境溼度 Ambient Humidity	35~65% RH (無冷凝 No condensation)				

## 外觀尺寸 External Dimensions

單位 Unit: mm

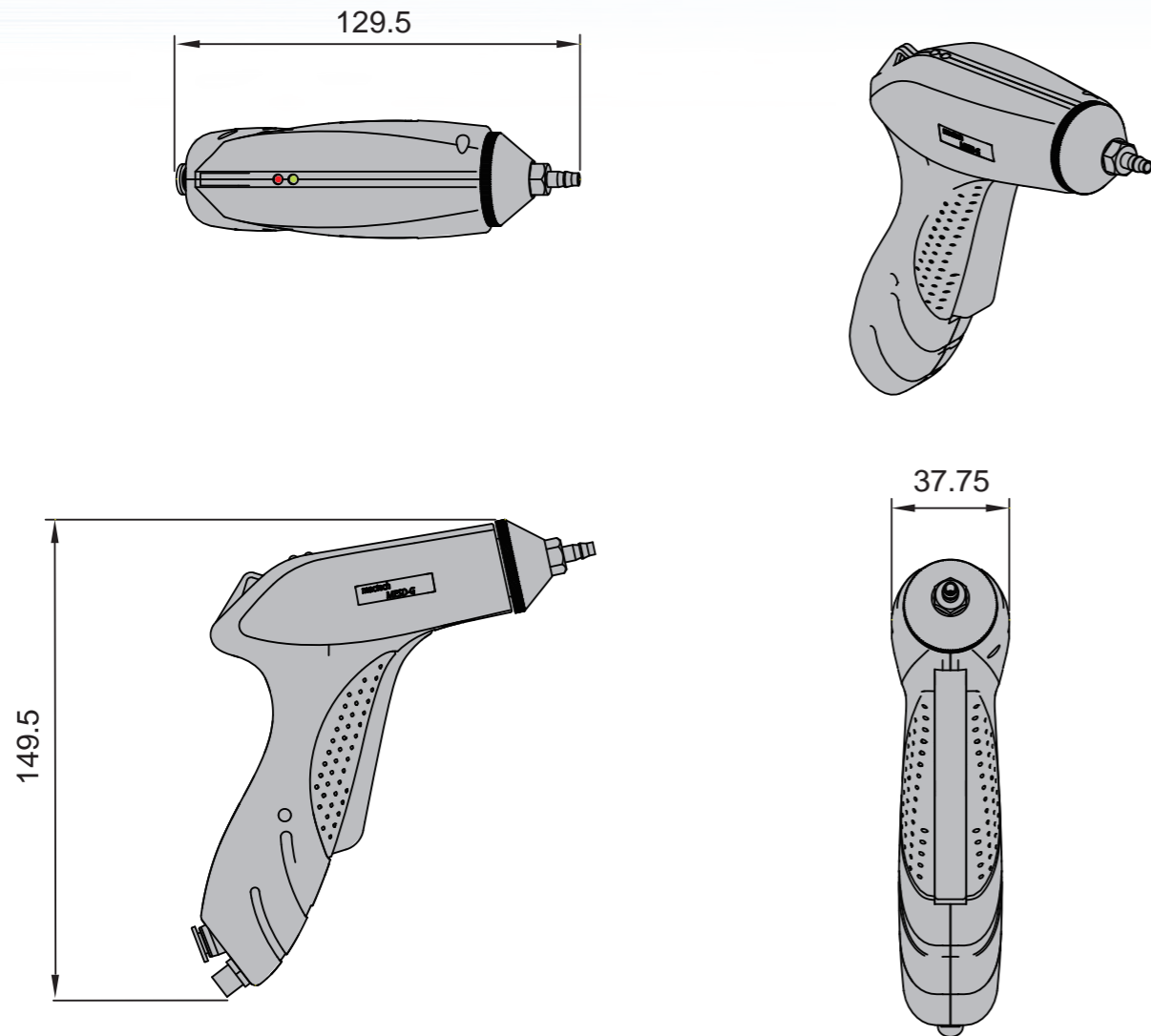

## 配件 Accessories

- 棒型  
Bar Type
- 區域型  
Area Type
- 扇型  
Fan Type
- 管型  
Tube Type
- 槍型  
Gun Type**

### 槍型標準配件 Gun Type Package Content

- ▶ 槍型電纜線 Power Cable (3 meter) MESD-CP025



### 電源選購配件 Power Supply Options

- ▶ 槍型電源供應器 Power Supply 24W MESD-CP025G



### 噴嘴選購配件 Nozzle Accessory Options

- ▶ 槍型標準型噴嘴組 Standard Nozzle MESD-NSTA



- ▶ 90° 擴散型噴嘴組 Spread Nozzle MESD-N90CA



- ▶ 120° 擴散型噴嘴組 Spread Nozzle MESD-N120A



- ▶ 90° 平式擴散型噴嘴組 Horizontal Spread Nozzle MESD-N90L



- ▶ 標準型噴嘴組 Standard Nozzle MESD-NSTA

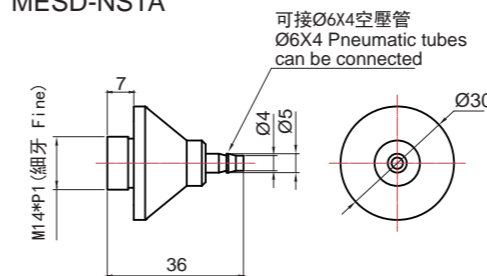

- ▶ 90° 擴散型噴嘴組 Spread Nozzle MESD-N90CA

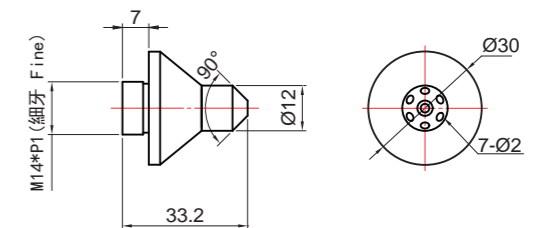

- ▶ 120° 擴散型噴嘴組 Spread Nozzle MESD-N120A

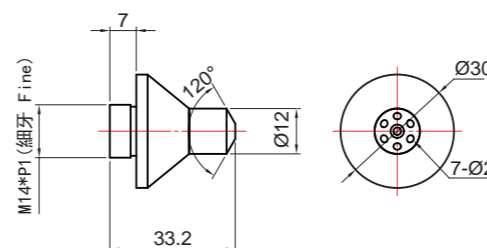

- ▶ 90° 平式擴散型噴嘴組 Horizontal Spread Nozzle MESD-N90L

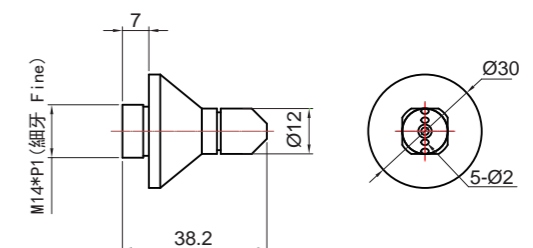

窄域定點型靜電消除器 Narrow Range Ionizer



# 靜電感應器 MESD-SE Static Sensor

靜電  
Static

振動  
Vibration

儀錶  
Meter



## 產品特色 Features

### 實現線上即時靜電管理 Achieve on-line static management

無需在靜電的測量和管理方面花費工時，即可適時監視肉眼無法看見的靜電。可通過適時監視來針對那些便攜式測量器難以測量的地方進行靜電管理。

A solution for timely monitoring the invisible static electricity which can replace man-hour with PC to measure and manage the static electricity. Via the static electricity management can be carried out for the place that is hard to timely monitoring by the portable measuring instrument.

### 簡易操作、輕鬆設定 Simple operation, Easy setting

採用一體化設計，具備判定輸出和異常輸出功能。無需通過放大器設備即可直接連接外部控制設備，節省總體空間。

Through integrated design, the static sensor could tell the output and abnormal output without amplifiers, to achieve saving space.

### 具有「數位輸出」和「類比輸出」兩種電壓數據 Two kinds of data: "digital output" and "analog output"

可以選擇與控制裝置之間的連接方式可以用做面向外部的判定輸出，或是利用電腦進行歷史記錄管理等。

You can choose the connection method with external control device, which can be used as judgment output or use a computer to manage history records.

### 判定輸出功能 Judgment output function

一旦超過設定電壓（臨界值），便會通過傳感器LED和電壓比較輸出（判定輸出）發出通知。

Sensor will send a notification through the LED and the voltage comparison input (judgment output) when setting voltage value is exceeded (threshold value).

### 歸零鍵功能 Zero key function

利用歸零鍵，可以將當前的測量值調整為0V。

Using the zero key, the current measured value can be adjusted to 0V.

靜電  
Static

振動  
Vibration

儀錶  
Meter

## 測量距離 Measuring distance

### 測量距離和電壓範圍 Measuring distance and voltage range

電壓範圍和解析度根據測量模式而變化。根據測量對象的電荷量設置測量距離。

The voltage range and resolution vary according to the measurement mode.

Set the measurement distance according to the charge amount of the measurement object.

測量距離 Measuring Distance (mm)	高精度模式 High Voltage Mode		標準模式 Standard Mode	
	範圍 Range (KV)	解析度 Resolution (V)	範圍 Range (KV)	解析度 Resolution (V)
10、25、40	±2.000	1	±20.00	10
60、100			±20.00	10

\*解析度是在測量超出測量範圍的物體時。如果被測物體小於測量範圍，則通過設置工件尺寸來輸出校正後的電荷量，但是解析度變粗糙。

另外，當充電量在±50V範圍內（在標準模式下為±500V）時，解析度比上表要粗糙。  
Resolution is when measuring an object that exceeds the measurement range. If the object being measured is smaller than the measurement range, the workpiece size can be set to compensate the amount of static charge that is output, but the resolution will degrade. Also, the resolution degrades at ±50V or below. (High voltage mode: ±500V or below)

### 測量距離和測量範圍 Measuring distance and measuring range

測量距離 Distance (mm)	測量範圍φ Range (mm)
10	30
25	120
40	240
60	320
100	400

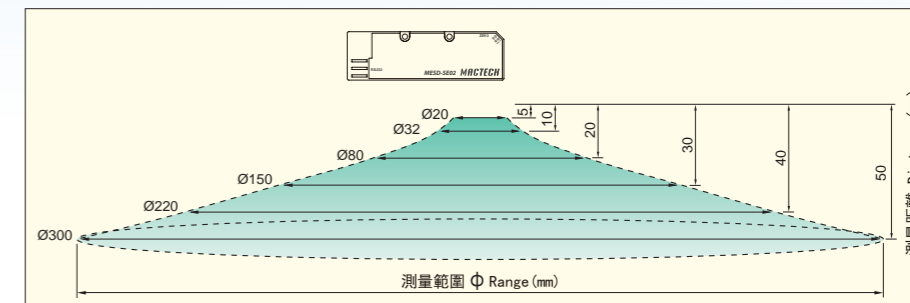

## 測量方法 Measuring methods

### 按測量模式的測量方法 Measurement method by measurement mode

將產品安裝在與設定的測量距離相同的位置。因測量值根據測量距離而變化，請將其安裝在正確的位置。

Install the product refer to measuring distance (the chart as below), the measured value vary according to the different measuring distance, then install the product to the appropriate position.

#### 高精度模式 High Voltage Mode

帶電量 Amount of Charge [KV]	類比輸出電壓 Analog Output Voltage [V]
測量距離 Measuring Distance 10~40mm	
+2.000	5.000
+1.500	4.500
+1.000	4.000
+0.500	3.500
+0.100	3.100
0	3.000
-0.100	2.900
-0.500	2.500
-1.000	2.000
-1.500	1.500
-2.000	1.000

#### 標準模式 Standard Mode

帶電量 Amount of Charge [KV]	類比輸出電壓 Analog Output Voltage [V]
測量距離 Measuring Distance 10~100mm	
+20.00	5.000
+15.00	4.500
+10.00	4.000
+5.00	3.500
+1.00	3.100
0	3.000
-1.00	2.900
-5.00	2.500
-10.00	2.000
-15.00	1.500
-20.00	1.000

靜電  
Static

振動  
Vibration

儀錶  
Meter

## 規格 Specifications

產品型號 Model	MESD-SE02	
輸入電源 Input Power	DC 12~24V	
測定距離 Operation range	10、25、40、60 mm (出廠預設25 mm)	
量測電壓 Voltage measurement	±2KV / ±20KV	
顯示解析能力 Sensitivity	1V / 10V	
輸出格式 Output mode	電壓 Voltage 1~5 V	
通訊功能 Protocol	Modbus RTU (RS485/RS232)	
通訊協定 Format	8-N-1	
傳輸速率 Transmission rate	115200 bps (預設值 Default)	
異常輸出接點 Power Safety Circuit	NPN電晶體出力 NPN transistor output*2 (Max. 20 mA)	
線性 Linear distortion	±3.5%	
應答時間 Response time	200 ms	
使用環境溫度 Ambient Temperature	0~50°C (室內 Indoor)	
使用環境溼度 Ambient Humidity	35~65% RH (無冷凝 No condensation)	

## 外觀尺寸 External Dimensions

單位 Unit: mm

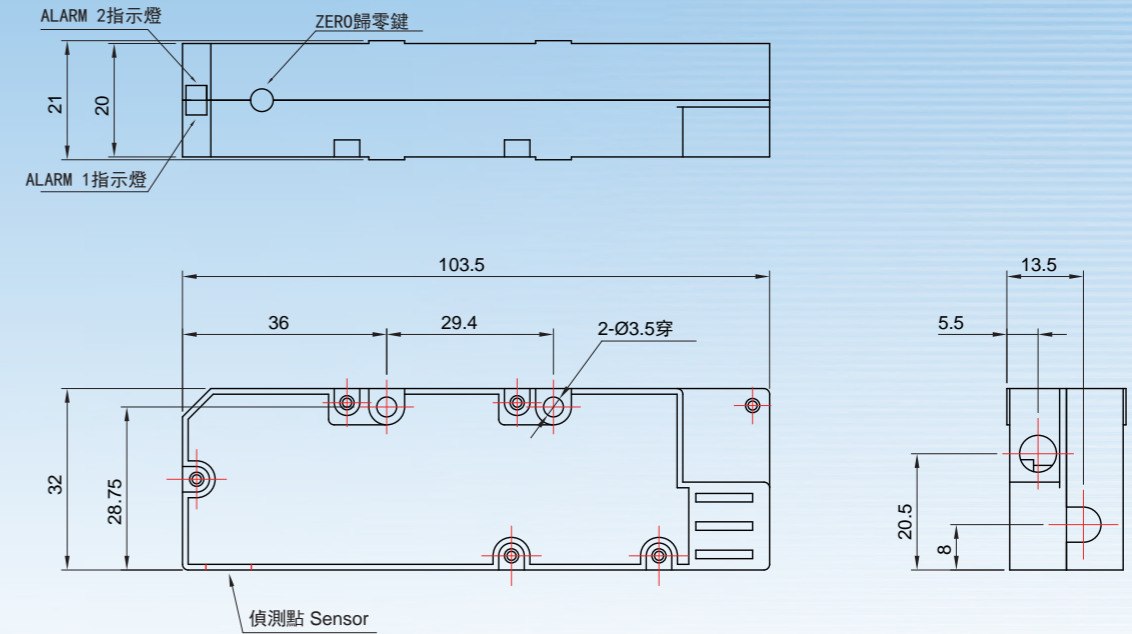

## 電路圖與接線圖 Circuit & Wiring Diagram

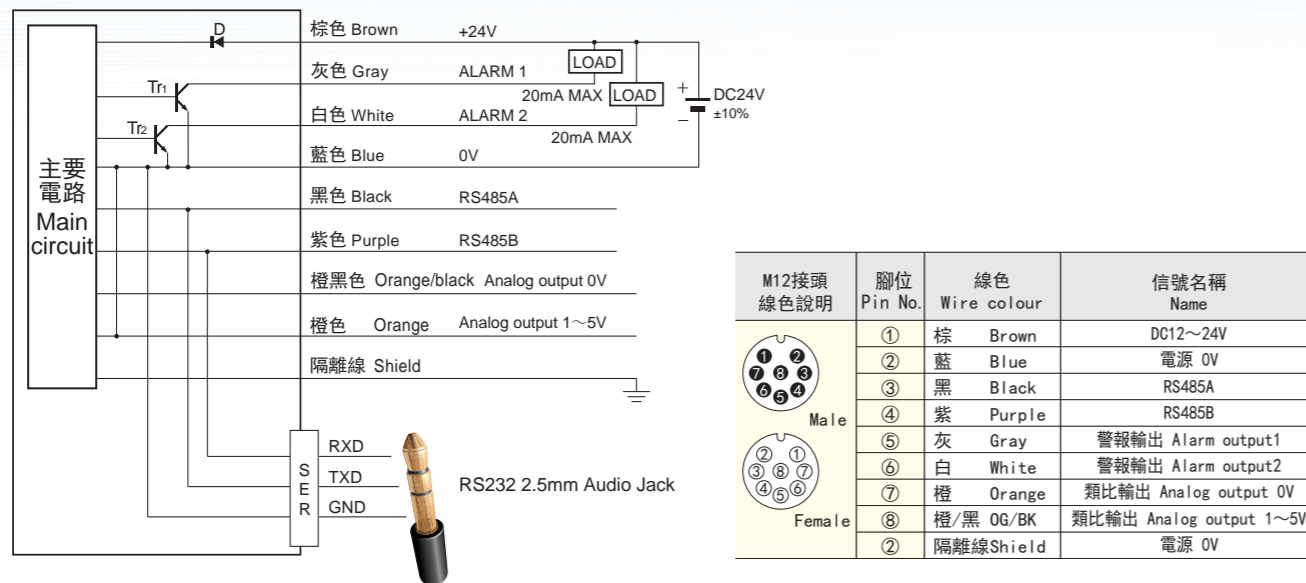

## 應用實例 Applications

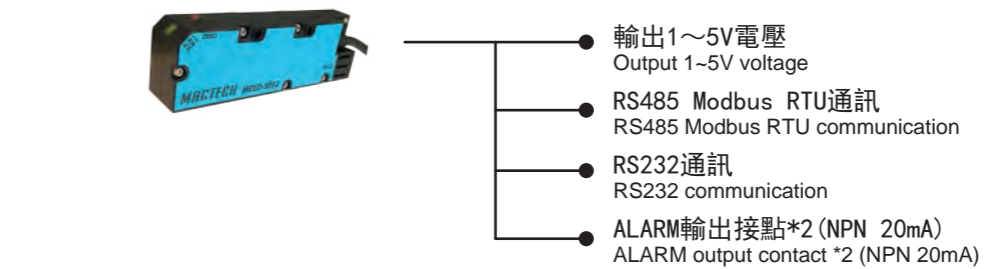

▶ 安裝於輸送帶機構  
Conveyor Operation

▶ 撕膜膠帶靜電消除  
Peeling Films Static Prevent

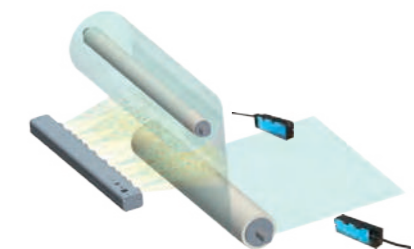
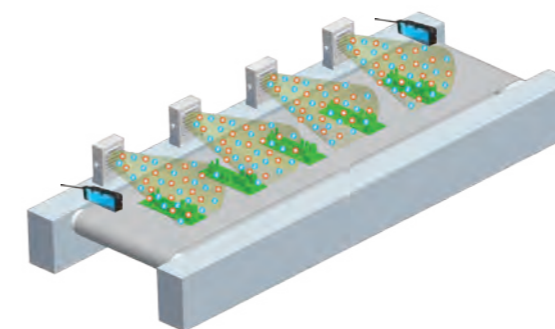

## 警報判斷 Alarm Judgment

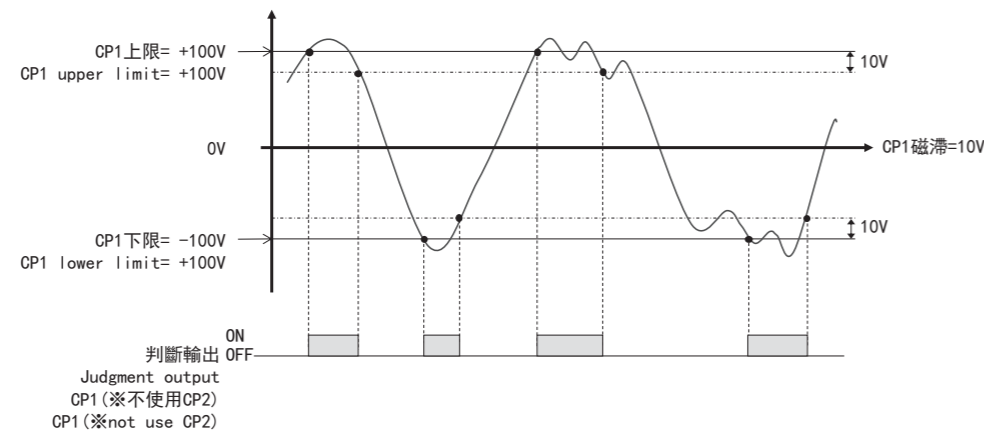



# 振動感測 MS-VS & MD Vibration Sensor

靜電  
Static

振動  
Vibration

儀錶  
Meter

靜電  
Static

振動  
Vibration

儀錶  
Meter



▶ MESD-METER



▶ MS-VS1



## 速度型 MS-VS1 Velocity type

測量範圍 Measuring range:  
400 mm/s (RMS)

- 最適監測目標 Optimal Target
- 軸承・齒輪箱・機床...等
  - Bearing·Gearbox·Machine tool...etc

■ 速度

速度型適合檢查旋轉機械的狀況。頻帶的目標為10至1000Hz，這是最廣泛使用的測量單位。可參考ISO 10816-1定義機械振動的評估指數。

- \* 需小量程可選擇
- MS-VS1A01, 測量範圍: 10mm/s
  - MS-VS1A05, 測量範圍: 50mm/s

The velocity type is suitable for checking the condition of rotating machinery. The frequency band is 10 to 1000 Hz, which is the most widely used unit for measurement. Please refer to ISO 10816-1 to define the evaluation index of mechanical vibration.

\* Others model for smaller measuring range.

- MS-VS1A01, Measuring range: 10mm/s
- MS-VS1A05, Measuring range: 50mm/s

## 加速度型 MS-VS2 Acceleration type

測量範圍 Measuring range:  
100 m/s<sup>2</sup>

- 最適監測目標 Optimal Target
- 電機・壓力泵・壓縮機...等
  - Motor·Pump·Compressor...etc

■ 加速度

加速度型用於測量較高頻率的振動，如軸承和齒輪箱。它適用於產生脈衝的振動，例如軸承磨損，刮痕或碎屑。

The acceleration type is used for measuring higher frequency vibrations such as bearings and gearboxes. It is suitable for pulsed vibrations such as bearing wear, scratches or debris.

## 位移型 MS-VS3 Displacement type

測量範圍 Measuring range:  
100 μm (P-P)

- 最適監測目標 Optimal Target
- 風機・鼓風機・振動試驗機...等
  - Fan·Blower·Vibration tester...etc

■ 位移

位移型表示振動的波動範圍，適用於測量風扇，鼓風機等的不平衡振動。頻帶很低，範圍從10Hz到幾百Hz。

\* 需較大位移型，可選擇 MS-VS3H, 量測範圍: 2mm (P-P)。

Displacement type represents the fluctuation range of vibration and is suitable for measuring unbalanced vibrations, such as fans and blowers, etc. The frequency band is very low, ranging from 10 Hz to hundreds Hz.

\* Others model for larger measuring range.

MS-VS3H, measuring range: 2mm (P-P).

## 自動監測設備 Automatic Monitoring Equipment

透過振動感測器24小時自動監測設備的振動頻率，藉此可以檢測設備是否有故障的現象。  
Via vibration sensor for 24 hours auto-monitoring to check the equipment is malfunction or not.

## 各類機器振動評定標準 Machinery Vibration Evaluation Standards

基於ISO 10816-1振動強度的絕對值評估（見下圖）是根據振動值判斷機器是好還是壞的方法之一。除此之外，基於正常時間的振動值，相對判斷方法也是常見的，其中2至3倍作為警示值且5至6倍作為異常值。  
The absolute value evaluation of vibration intensity based on ISO 10816-1 (see the figure below) is one of the methods to judge whether the machine is good or bad based on the vibration value. In addition, based on normal time vibration values, relative judgment methods are also common, where 2 to 3 times are used as warning values and 5 to 6 times are used as abnormal values.

### 迴轉類型機械的典型評價區及其範圍

Typical evaluation area and scope of rotary type machinery 單位Unit: mm/s (RMS)

	0.28	0.45	0.71	1.12	1.8	2.8	4.5	7.1	11.2	18	28	45	
I	Blue	Blue	Blue	Green	Green	Orange	Orange	Red	Red	Red	Red	Red	優
II	Blue	Blue	Blue	Green	Green	Orange	Orange	Red	Red	Red	Red	Red	良
III	Blue	Blue	Blue	Green	Green	Orange	Orange	Red	Red	Red	Red	Red	可
IV	Blue	Blue	Blue	Green	Green	Orange	Orange	Red	Red	Red	Red	Red	不可

①評估區劃分如下

- 優: 新建機器的振動值
  - 良: 沒有任何限制，可以長期運行
  - 可: 無法長期連續工作
  - 不可: 嚴重到足以造成損害
- The assessment area is divided as follows
- Excellent: Newly commissioned machine
  - Acceptable: Unrestricted long-term operation
  - Unsatisfactory: Restricted long-term operation
  - Unacceptable: Vibration causing damage

②機械分類如下

- I類: 小型機器、電動機; ≤15KW。
  - II類: 中型機器、電動機; 15~75KW。
  - III類: 剛性支撐的大型機器; 75~300KW
  - IV類: 彈性支撐的透平機。
- The mechanical classification is as follows
- Class I: Small machines, motors; ≤15KW.
  - Class II: Medium-sized machines, motors; 15~75KW.
  - Class III: Large machines with rigid support; 75~300KW
  - Category IV: Elastically supported turbines.

③本圖基於ISO 10816-1。要確定區域邊界，請適當考慮機床製造商的要求和安裝環境。

This picture is based on ISO 10816-1. To determine the regional boundary, please consider the requirements of the machine tool manufacturer and the installation environment.

## 實現低成本測振系統 Achieve Low-cost Vibration Monitoring System

集中監測工廠設備的振動系統可以低成本實現。  
The vibration system aims at centralized monitoring for the equipment of factory to reduce the cost.

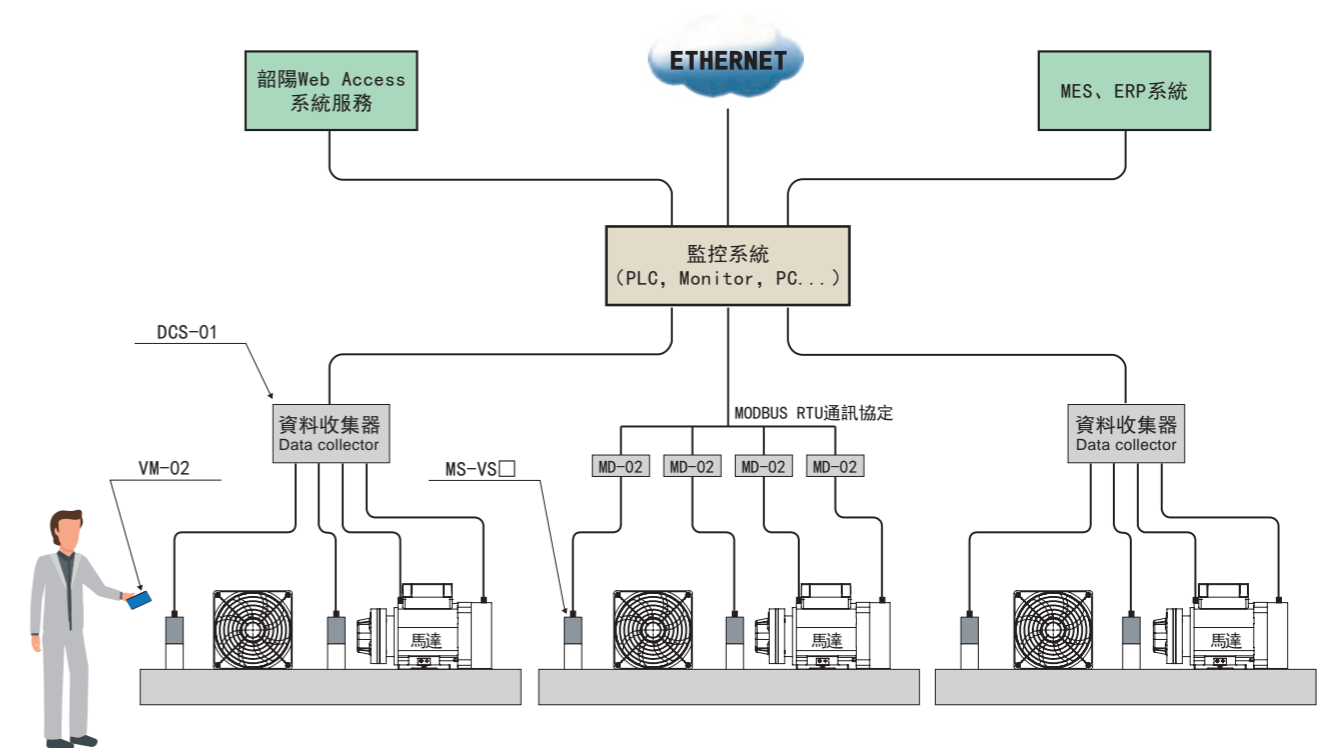

# 振動感應器 MS-VS Vibration Sensor

靜電  
Static

振動  
Vibration

儀錶  
Meter



► MS-VS

## 產品特色 Features

- 產線自動量測；2線式出線，配線簡易。  
Auto-detection.
- 防水防塵耐酸鹼。  
Water-proof, Dust-proof and Acid & alkali resistant.
- 感測器內建放大器電路，因此不需要單獨的振動計放大器。  
Built-in amplifier circuit, so there is no need for a separate vibration meter amplifier.
- 適合多種產能，檢測環境。  
Vibration sensor can be applied to various production line.
- 搭配儀錶簡易操作介面，操作按鍵即可輕鬆設定。  
Easy operation interface with meter.
- 搭配儀錶可設定振動上下限警報，產線管理更容易。  
With meter easily to manage the production line by setting the upper and lower vibration alarm limits.
- 搭配MESD-METER或資料收集器可支援Modbus RTU通訊協定，連接外部PC、PLC資料收集、記錄與判讀。  
With MESD-METER or DCS-01 can support Modbus RTU, connect with PC or PLC to collect and analyze data.

## 使用範圍 Applications

- 廠房需佈設的檢測點數量較多，為減少人力成本，使用振動感測器進行自動監測。  
If the inspection points are more, owing to reduce the cost, replace man-hour with vibration sensor to do 24 hours auto-monitoring.
- 檢測的位置位於高處或危險處。  
The inspection point is located in a high or dangerous place.
- 蝕刻機、機械手臂、工具機、馬達振動異常。  
Abnormal vibration of the etching machine, mechanical arm, machine tool, and motor.
- PCB電鍍、高科技樓板、晶圓搬運。  
PCB plating, high-tech floor, wafer handling.
- 數位化的設備維護管理。  
Digital equipment maintenance and management.
- 24小時自動監測，定期及時更換部件來降低成品不良及維護成本。  
24-hour automatic monitoring, regular and timely replacement of parts to reduce product defects and maintenance costs.

## 規格 Specifications

產品型號 Model	MS-VS1	MS-VS2	MS-VS3
輸入電源 Input Power	DC 9~28V		
型式 Style	速度型 Velocity	加速度型 Acceleration	位移型 Displacement
量測範圍 Sensor Area	10, 50, 400 mm/sec	100 m/s <sup>2</sup>	100 μm
靈敏解析能力 Sensitivity	20 mV / (mm/sec)	0.01 m/s <sup>2</sup>	0.01 μm
頻率響應 Frequency	10~1K Hz (單向 Unidirection)	10~2K Hz	10~2K Hz
輸出模式 Output Mode	DC 4~20 mA		
線性失真 Linear Distortion	≤3%		
應答時間 Damping	20 ms (毫秒)		
安裝螺紋 Screw Thread	M8		
使用環境溫度 Ambient Temperature	-30~85°C (室內 Interior)		
使用環境溼度 Ambient Humidity	35~65% RH (無冷凝 No condensation)		

靜電  
Static

振動  
Vibration

儀錶  
Meter

## 外觀尺寸 External Dimensions

單位 Unit : mm

► MS-VS

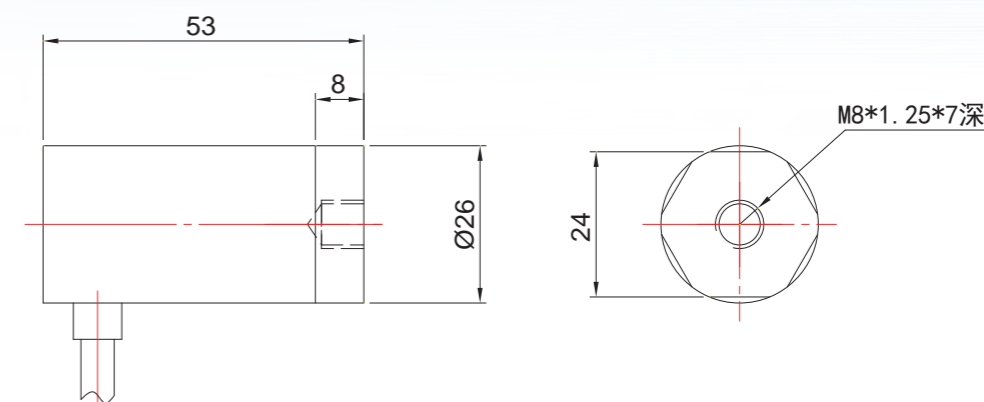

## 應用實例 Applications

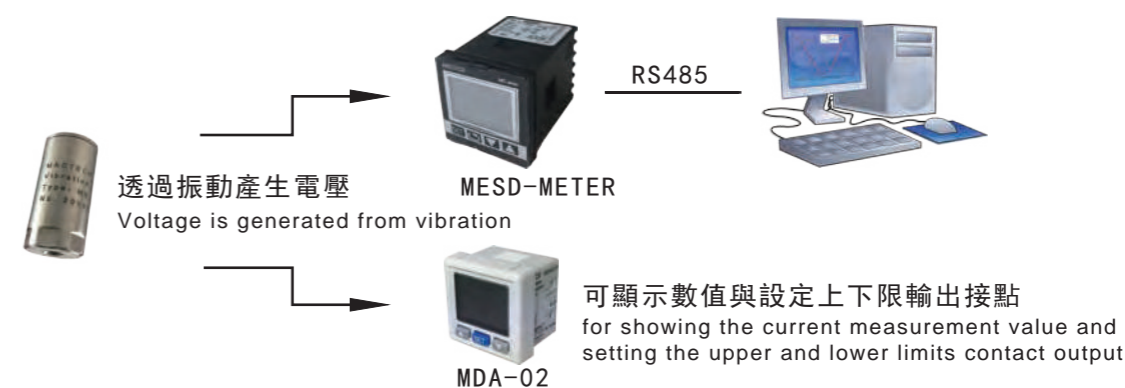



靜電  
Static

振動  
Vibration

儀錶  
Meter



▶ MESD-METER



▶ MDA



## 規格 Specifications

產品型號 Model		MESD-METER	
		搭配靜電感測器時 (Static sensor)	搭配振動感測器時 (Vibration sensor)
量測範圍	Measuring range	±1.999 / ±19.99 KV (Unit auto-conversion)	Max 400 mm/sec
量測週期	Period	10 ms (毫秒)	100 ms (毫秒)
通訊功能	Protocol	Modbus RTU (RS485)	
通訊協定	Format	8-N-1	
傳輸速率	Transmission rate	9600, 19200, 38400, 57600 bps... Max 115200 bps (預設值 Default)	
輸出警報	Output mode	繼電器 (2組) Relay * 2	
顯示器	Display	三色 LCD 面板 Color LCD panel	
電源/消耗功率	Power / consumption	AC 100~240V / 0.2VA	
安裝距離設定	Installed size	10~40mm 7段設定 (7-stages setting)	-
安裝開孔尺寸	Installed size	48 x 48 mm (標準孔位 Standard type)	
使用環境溫度	Ambient temperature	0~40°C (室內 Indoor)	
使用環境濕度	Ambient humidity	35~65% RH (無冷凝 No condensation)	

產品型號 Model		MDA-01	MDA-02
量測範圍	Measurable range	Max 9.99 KV	Max 100 mm/sec
顯示週期	Period	1 sec	100、250、500、1,000 ms (毫秒)
量測精度	Output mode	0.01 KV	± 3% 全量程
輸出反應時間	Transmission rate	1、5、10、50、100、200、500、1000、3,000、5,000 ms	
顯示器	Display	三色 LCD 面板 Color LCD panel	
電源/消耗功率	Power / consumption	DC 12~24V / 40 mA Max	
安裝開孔尺寸	Installed size	30 x 30 mm (標準孔位 Standard type)	
使用環境溫度	Ambient temperature	0~40°C (室內 Indoor)	
使用環境濕度	Ambient humidity	35~65% RH (無冷凝 No condensation)	

## 產品特色 Features

- 簡易操作介面，操作按鍵即可輕鬆設定。  
Easy operation interface.
- 設定上下限警報，產線管理更容易。  
Easily to manage the production line by setting the upper and lower alarm limits.
- 支援Modbus RTU通訊協定，可連接外部PC、PLC資料收集、記錄與判讀。  
Support Modbus RTU communications protocol and connect with PC or PLC to collect and analyze data.

## 使用範圍 Applications

- 靜電感測器。  
Static seneor
- 振動感測器。  
Vibration seneor

## 外觀尺寸 External Dimensions

單位 Unit: mm

▶ MESD-METER

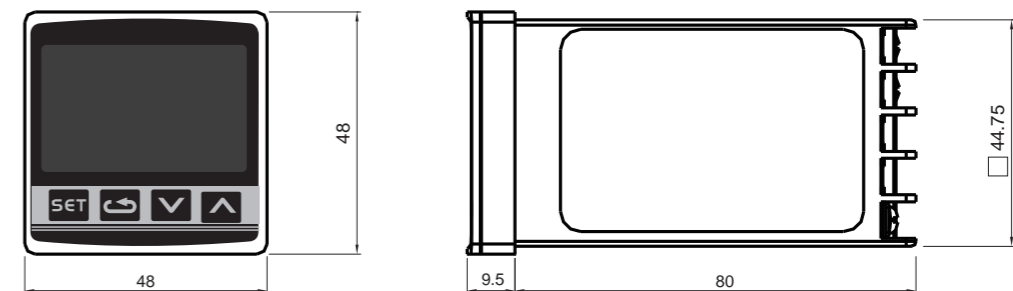

▶ MDA

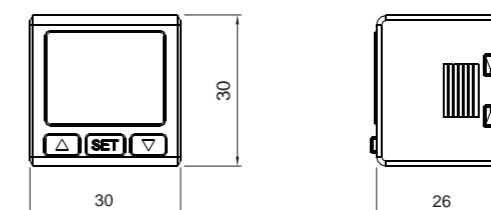

### 規格 Specifications

產品型號 Model		MESD-TA02	
輸入電源 Input Power	9V Battery		
消耗電流 Current Consumption	14 mA		
靜電量測距離 Measuring Distance	2.54 mm		
靜電量測範圍 Range of Measure Static	高量程 High Range	低量程 Low Range	
	±0~2 KV/inch	±0~20 KV/inch	
量測顯示範圍 Voltage Display Range	±0~1.999 KV/inch		±0~19.99 KV/inch
	顯示解析度 Display Resolution	1 V/inch	10 V/inch
介面顯示 LED Indicator	三位半LED顯示器 3½ digit LED display		
量測精度 Precision	±5%		
採樣頻率 Sampling Rate	每秒3次 3 readings per second		
使用環境溫度 Ambient Temperature	10~30°C (室內 Indoor)		
使用環境溼度 Ambient Humidity	35~65% RH (無冷凝 No condensation)		

靜電  
Static

振動  
Vibration

儀錶  
Meter

靜電  
Static

振動  
Vibration

儀錶  
Meter

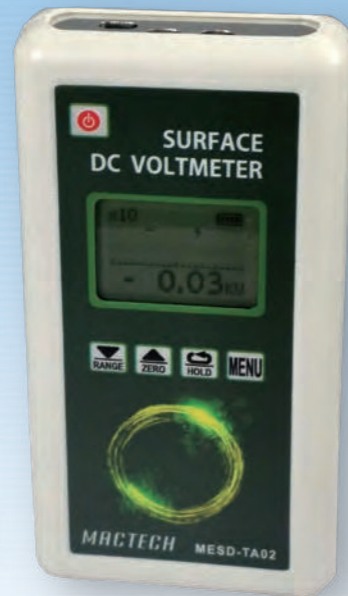

### 產品特色 Features

手持式靜電量測儀，以非接觸式方式，透過測量目標表面的靜電位，來檢測目標物的靜電電壓。  
Hand-held Electrostatic field meter is a non-contact device. It is designed to measure the electrostatic voltage on an object surface.

- 體積輕巧、攜帶方便  
It is a pocket device, convenient to hand carry.
- 可鎖定靜電偵測值  
Press the hold-button to hold the value makes it easy to monitor.
- 數位型歸零鍵  
Digital zeroing key.
- 20分鐘未使用即自動關機  
Ecodesign, standby-mode over 20 minutes.
- LED測距功能可指示量測儀到被測物之間的距離  
Distance ranging system utilizes LEDs to indicate a spacing between the instrument and the test target.
- 平衡測試選配套件可測試靜電消除器的平衡電壓  
It can also be used for testing balance and +/- decay capabilities of ionizers when the optional Ionizer Test Kit is ordered.

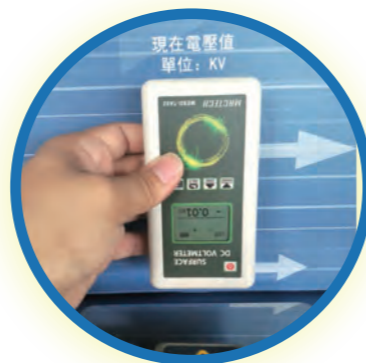

### 外觀尺寸 External Dimensions

單位 Unit: mm

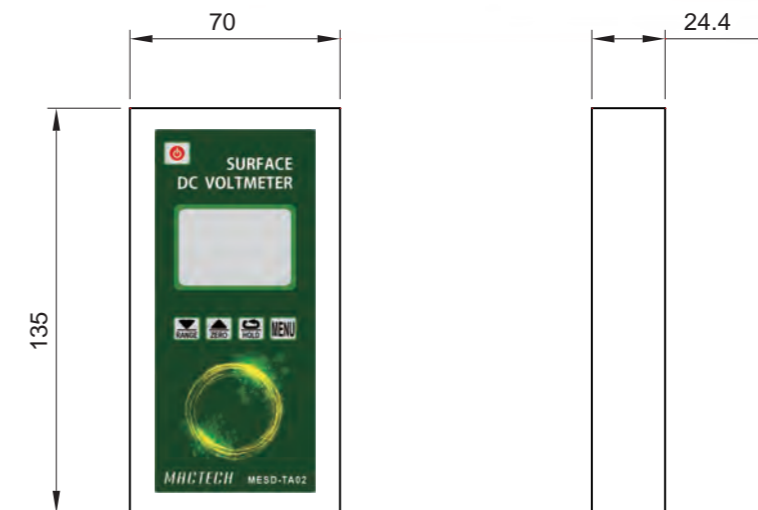

### 使用範圍 Applications

- 進料器之靜電量測  
Feeding measuring
- 輸送帶、滾輪除塵...等靜電量測  
Conveyor, rolling machines measuring
- 工作平台、製品...等靜電量測  
Working table, products measuring
- 撕膜、貼膜、基板...等靜電量測  
Peeling films, lamination, panel or glass substrate measuring





靜電  
Static

振動  
Vibration

儀錶  
Meter



## 規格 Specifications

產品型號 Model	VM-02	
量測範圍 Measurable Range	加速度 Acceleration: 0.1~400 m/s <sup>2</sup> , 峰值 Peak 0.3~1312 ft/s <sup>2</sup> , 0.0~40 g 速度 Velocity: 0.01~400 mm/s, 真有效值 True RMS 0.004~16.0 inch/s 位移 Displacement: 0.001~4.0 mm, 峰值 Peak 0.04~160.0 mil 頻率 Frequency: 5~1K Hz	
頻率範圍 Frequency Range	加速度 Acceleration: 10~1K Hz / 10~10K Hz (x10模式用於軸承檢查) 速度 Velocity: 10~1K Hz ; 位移 Displacement: 10~1K Hz	
單位切換 Unit	公制 / 英制 Metric / Imperial	
量測精度 Precision	±5% + 2位數	
顯示器 Display	單色LCD 白色背光 4 digital LCD backlight	
通訊功能 Protocol	RS-232	
輸出 Output Mode	2.0V 交流負載電阻 AC load resistance: above 10K	
電源 Power	1.5V 3號電池(AA)*2	
使用環境溫度 Ambient Temperature	0~50°C (室內 Indoor)	
使用環境濕度 Ambient Humidity	35~85% RH (無冷凝 No condensation)	

靜電  
Static

振動  
Vibration

儀錶  
Meter

## 產品特色 Features

- 液晶LCD顯示，重量輕，操作簡單。  
Liquid crystal LCD display, light weight and simple operation.
- 可同時顯示「位移」、「速度」和「加速度」三參數。  
It can display three parameters of "Displacement", "Velocity" and "Acceleration" at the same time.
- 使用壓電加速度感測器轉換成振動信號。  
A piezoelectric acceleration sensor is used to convert into a vibration signal.
- 量測頻率範圍寬，加速度模式下頻率可達10~10KHz。  
The measurement frequency range is wide, and the frequency can reach 10-10KHz in acceleration mode.
- 支援RS-232，可連接外部PC資料記錄與判讀。  
Support RS-232, can be connected to external PC data recording and interpretation.
- 量測儀含強力磁鐵、M6螺絲、探針，適合各種場合。  
The measuring instrument contains powerful magnet, M6 screw and probe, suitable for various occasions.

## 使用範圍 Applications

- 蝕刻機、機械手臂。  
Etching machine, mechanical arm.
- 工具機、馬達振動異常。  
Abnormal vibration of machine tool and motor.
- PCB電鍍、高科技樓板。  
PCB plating, high-tech floor.
- 晶圓搬運。  
Wafer handling.

## 外觀尺寸 External Dimensions

單位 Unit: mm

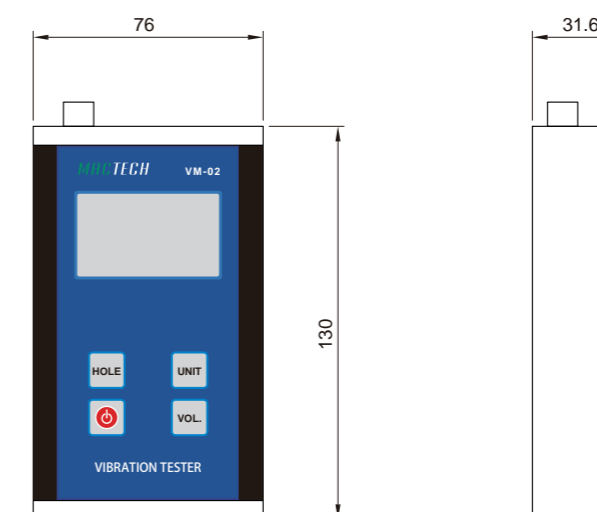



以「紅外線光學鏡片」技術為基礎的薄型光幕  
Base on 「Infrared optical lens」  
technology-based of thin type light curtains

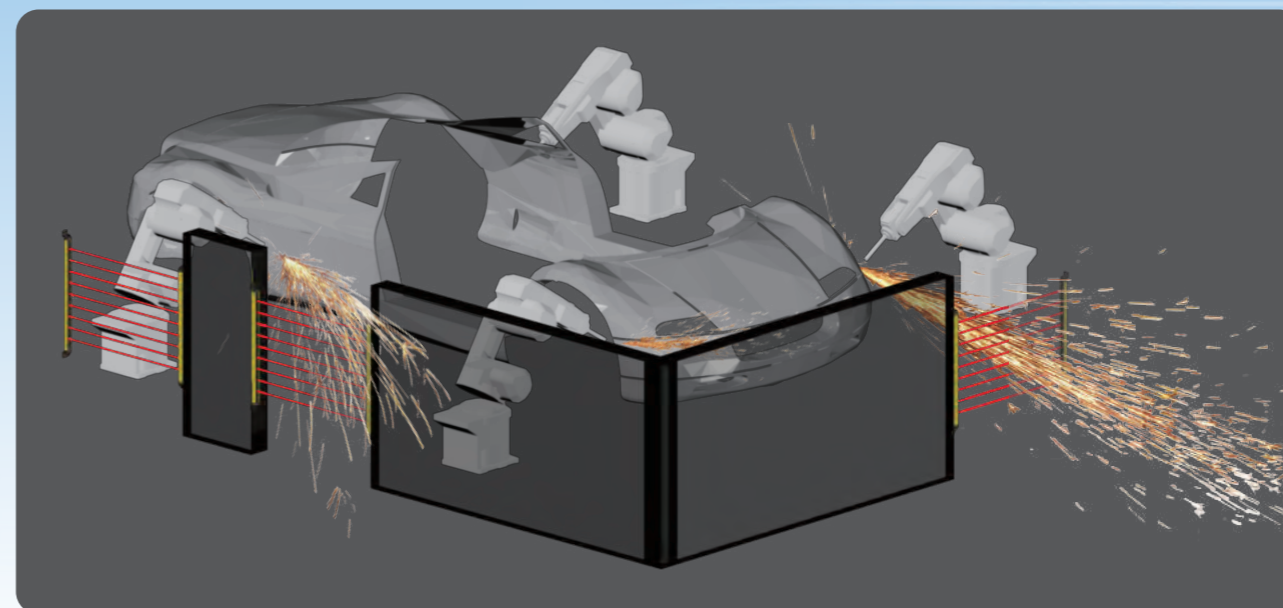

## 產品特色 Features

- 厚度僅18mm薄型光柵內置光學鏡片設計：節省空間、提升運作距離、強化偵測能力。  
Thickness of only 18mm: Built-in optical lens / Improve protective field width and the ability to detect
- 指示燈號完全對應：更方便查看光柵狀態。  
Indicator lights correspond exactly: Easy to monitor
- 短路過電流+鎖死偵測，提高安全可靠。  
Output Protection circuit: Reverse current / Short circuit / Overload

## 使用範圍 Applications

- 沖床機械、切紙機械、皮革機械、木工機械、鍛壓機床、紡織機械等。  
Punching, paper cutting, leather, woodworking, forging machine tools, textile machinery.
- 自動化設備、生產線、碼垛系統。  
Automation equipment, production lines, palletizing systems.
- 電梯、升降台。  
Elevator, lift.
- 禁區、風險區域。  
Restricted area, risk area.

## 規格 Specifications

項目 Items	規格 Specifications
輸入電源 Input Power	DC 24V (範圍 Valid 18~26V)
消耗電流 Current Consumption	接收器最大 0.1A / 發射器平均 0.1A (瞬間 0.2A) Receiver Max. 0.1A / Emitter Average 0.1A (Peak 0.2A)
光軸間距 Beam Gap	20 / 40 mm
偵測能力 Detection Capability	ø25 / ø45 mm
運作距離 Operation Distance	0.1~6 m (SLC-24-M口2 / SLC-12-M口4以上 0.1~3 m)
有效光圈角度 Max Aperture Angle	Max. ±3° (運作距離 3 m 以上時 Operating distance over 3 m)
回應時間 Response Time	Max. 14 ms
光源 Light Source	紅外線 Infrared LED (940 nm)
OSSD輸出 OSSD Output	NPN/PNP共用接點 NPN/PNP common type 最大負載 MAX. load current 80 mA
保護電路 Protection Circuit	逆電流保護、輸出短路保護、防燒毀鎖死 Reverse current protection, short-circuit protection, surge protection
安全規格 Safety	EN61496-1 Type 4 ESPE
外殼顏色 Color	亮黃 Bright Yellow
使用環境溫度 Ambient Temperature	15~40°C (室內 Indoor)
使用環境溼度 Ambient Humidity	35~65% RH (無冷凝 No condensation)



## 外觀尺寸 External Dimensions

單位 Unit: mm

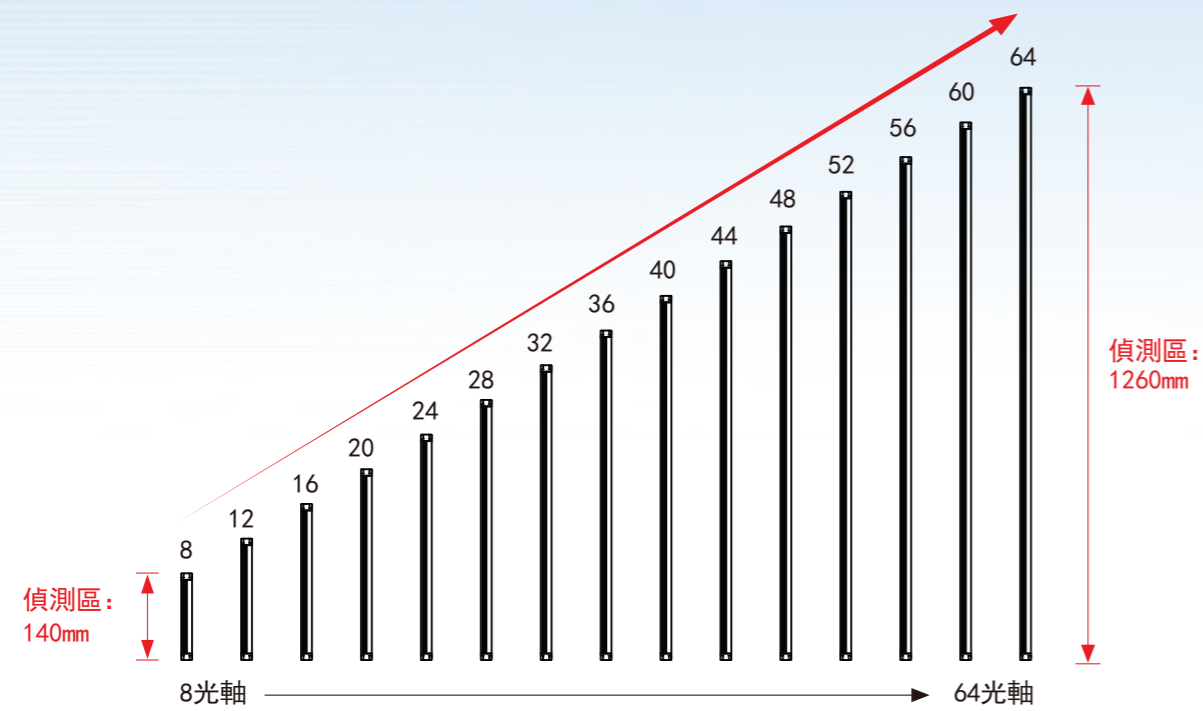
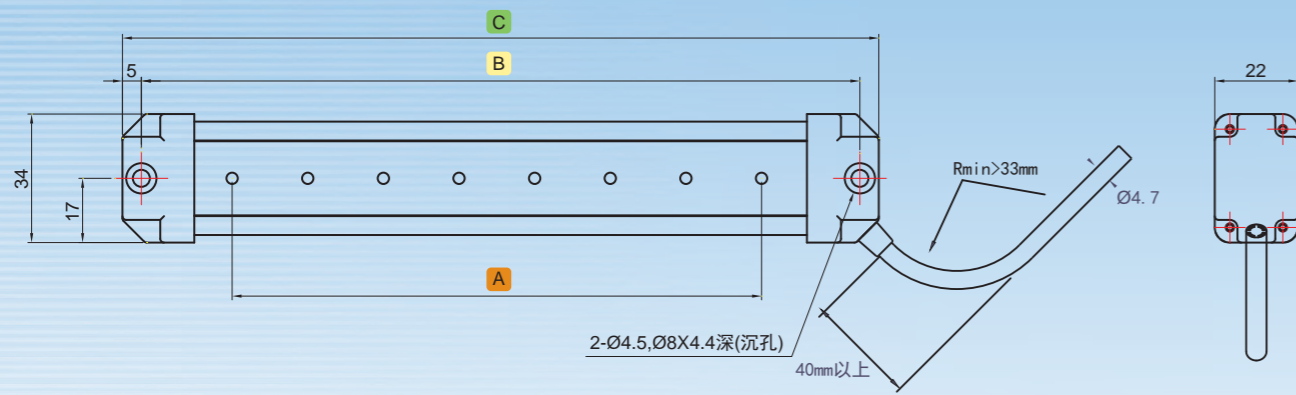

## 選購資訊 Ordering information

SLC - 1 - 2 3 4

項目 Item	說明 Description
1 光軸數 Number of Beam	08~64
2 出線型式 Outlet Type	M: M12 轉接插頭 (5pin、不可併接延伸) L: M12 轉接插頭 (8pin、可併接延伸 for series)
3 OSSD 輸出型式 OSSD Output	N: NPN output P: PNP output
4 光軸間距 Beam Gap	2: 20mm 4: 40mm

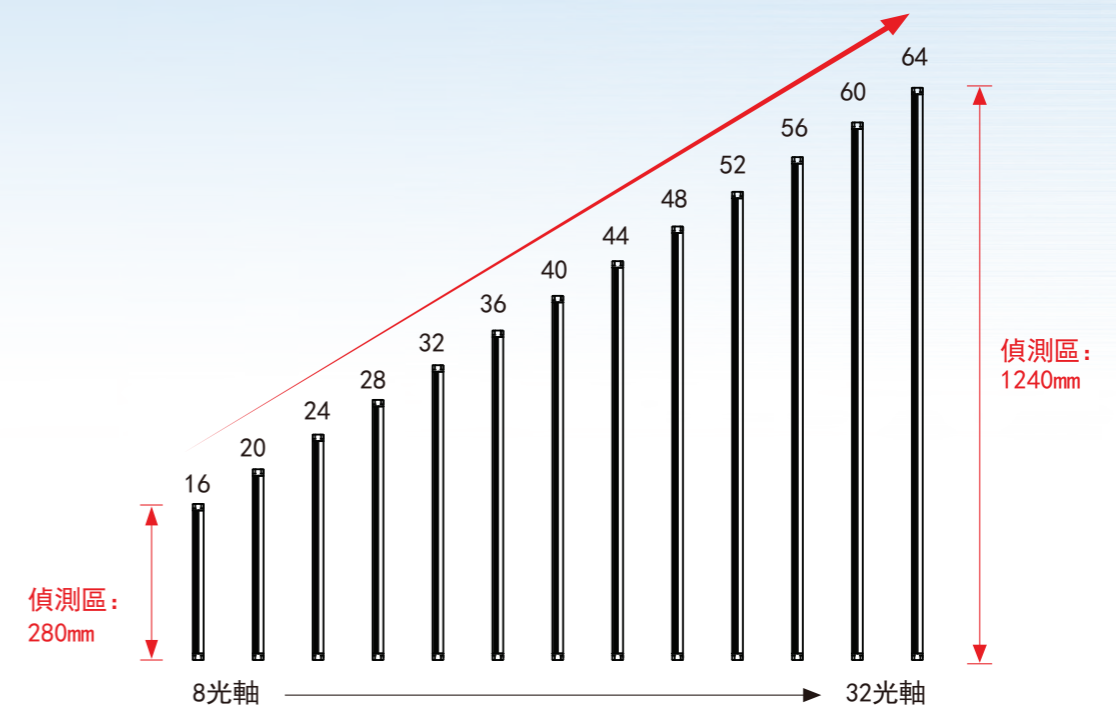

型號 Model	運作距離 Operation Distance	光軸數目 Number of Beam	A 偵測區 Detection Area	B 安裝間距 Install Distance	C 總長 Total Length
SLC-08-M□2	0.1~6M	8	140	183	193
SLC-12-M□2		12	220	263	273
SLC-16-M□2		16	300	343	353
SLC-20-M□2		20	380	423	433
SLC-24-M□2		24	460	503	513
SLC-28-M□2	0.1~3M	28	540	583	593
SLC-32-M□2		32	620	663	673
SLC-36-M□2		36	700	743	753
SLC-40-M□2		40	780	823	833
SLC-44-M□2		44	860	903	913
SLC-48-M□2		48	940	983	993
SLC-52-M□2		52	1020	1063	1073
SLC-56-M□2		56	1100	1143	1153
SLC-60-M□2		60	1180	1223	1233
SLC-64-M□2		64	1260	1303	1313

型號 Model	運作距離 Operation Distance	光軸數目 Number of Beam	A 偵測區 Detection Area	B 安裝間距 Install Distance	C 總長 Total Length
SLC-08-M□4	0.1~6M	8	280	343	353
SLC-10-M□4		10	360	423	433
SLC-12-M□4		12	440	503	513
SLC-14-M□4	0.1~3M	14	520	583	593
SLC-16-M□4		16	600	663	673
SLC-18-M□4		18	680	743	753
SLC-20-M□4		20	760	823	833
SLC-22-M□4		22	840	903	913
SLC-24-M□4		24	920	983	993
SLC-26-M□4		26	1000	1063	1073
SLC-28-M□4		28	1080	1143	1153
SLC-30-M□4		30	1160	1223	1233
SLC-32-M□4		32	1240	1303	1313

## 消耗電流與重量 Consumption Current and Weight

型號 Model	回應時間 (OSSD) Response time	消耗電流 Consumption Current (mA)		重量 Approx. Weight (g)	
		發射器 Transmitter	接收器 Receiver	發射器 Transmitter	接收器 Receiver
SLC-08	Max. 14 ms	30	26	109	109
SLC-12		30	27	144	145
SLC-16		30	28	174	175
SLC-20		30	30	209	211
SLC-24		30	31	239	241
SLC-28		30	32	274	277
SLC-32		30	35	304	307
SLC-36		30	36	339	343
SLC-40		30	38	369	373
SLC-44		30	39	404	409
SLC-48		30	40	434	439
SLC-52		30	41	469	475
SLC-56		30	44	499	505
SLC-60		30	45	534	541
SLC-64	30	47	564	571	

## 指示燈 Indicator

指示燈號完全對應：更方便查看光柵狀態。  
Indicator lights correspond exactly: Easy to monitor

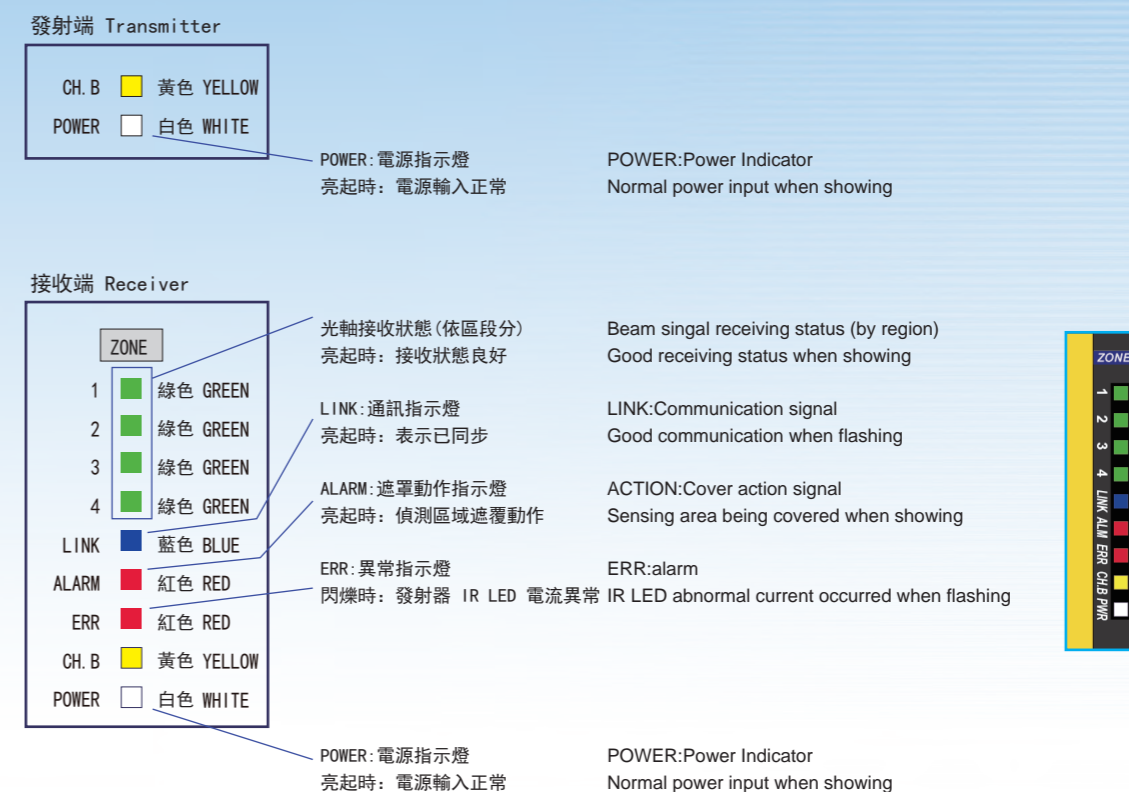

## 配件 Accessories

### 標準配件 Package Content

- ▶ 光柵M12信號線 Power Cable (2 meter)  
CBL-M12B-02M



(光柵本體出線為M12 pigtail型式, 線長300mm)

### 選購配件 Options Parts

- ▶ 光柵M12信號線-5M Power Cable (5 meter)  
CBL-M12B-05M



- ▶ 光柵M12信號線-10M Power Cable (10 meter)  
CBL-M12B-10M



## 基本電路圖 (For PNP OUTPUT) I/O Circuit Diagram

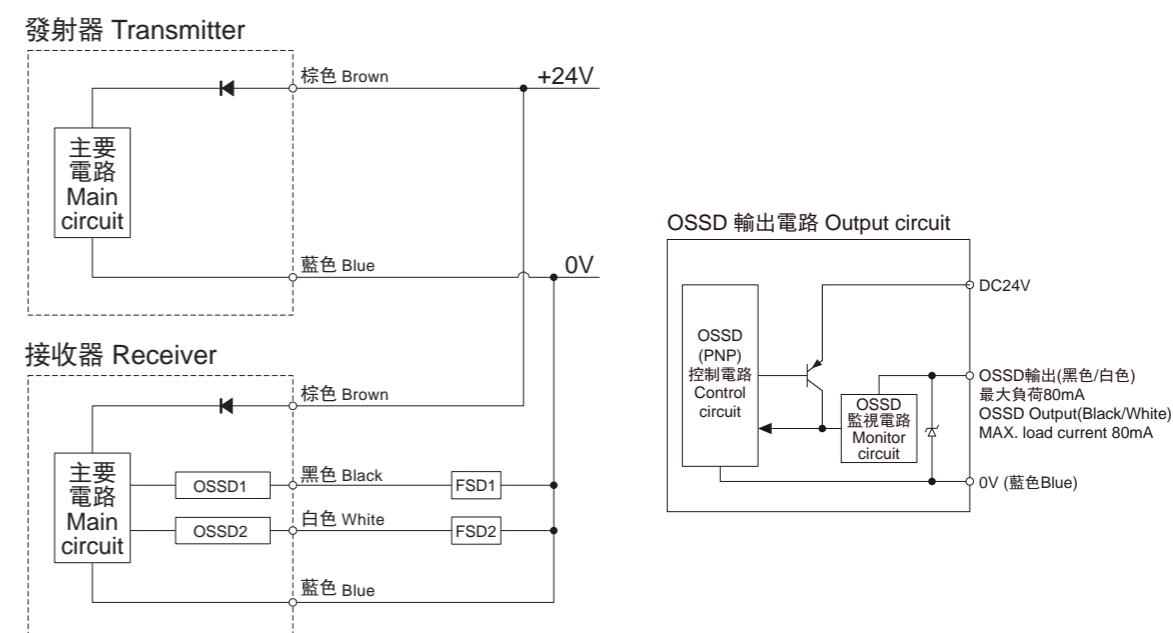



### 基本接線圖 (For PNP OUTPUT) Wiring Diagram

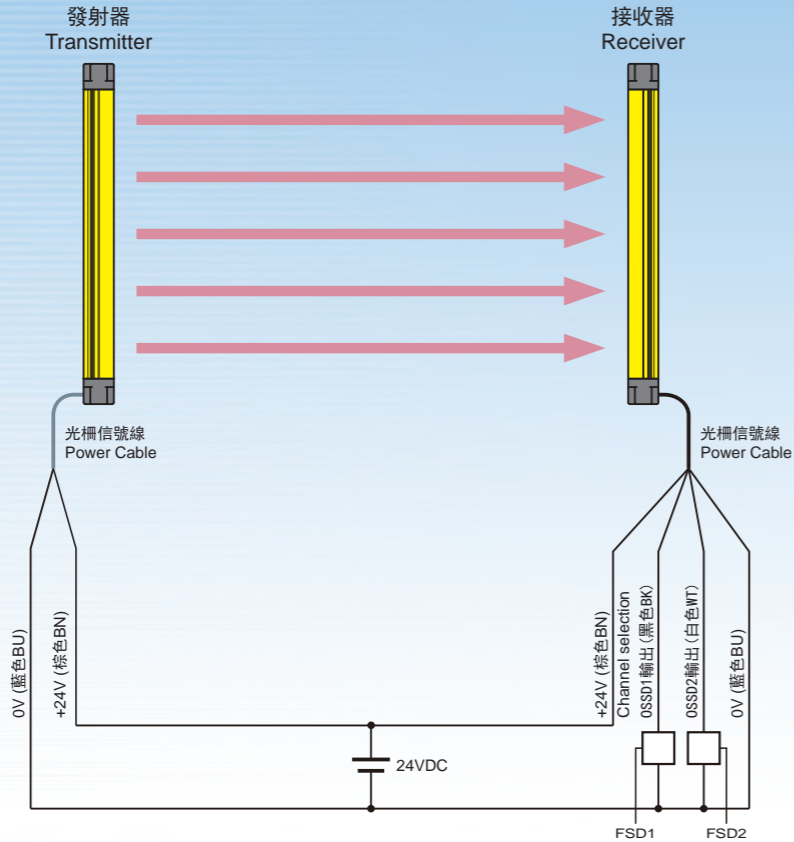

### 簡單的線路連接範例 Simple Wiring Example

PNP或NPN輸出請於訂購時註明。  
Please specify PNP or NPN output when ordering.

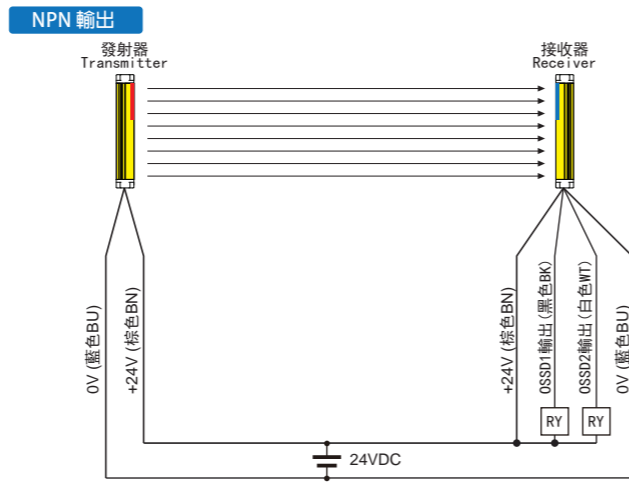
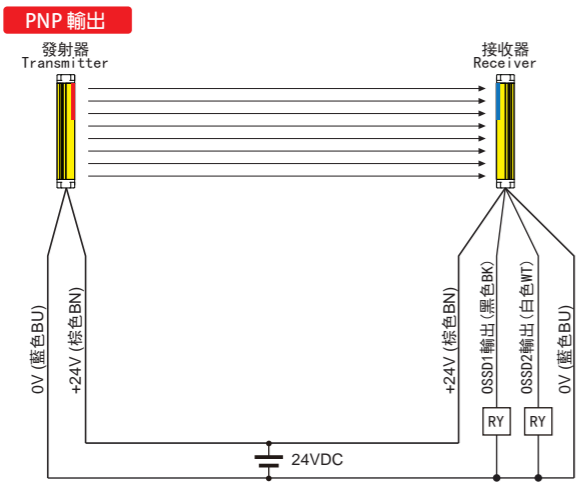

配線時除棕色線接+24V，藍色線及隔離線接0V外，其餘皆不可接至電源，未使用之線線須確實做好絕緣保護，否則將導致設備損壞。  
When wiring, the brown wire is connected to +24V, the blue wire and the isolated wire are connected to 0V, and the rest should not be connected to the power supply. Unused cables must be properly insulated, otherwise the equipment will be damaged.

NPN配線時OSSD輸出接+24V，未使用之線線須確實做好絕緣保護，否則將導致設備損壞。  
When NPN wiring, the OSSD output is connected to +24V. The unused cables must be properly insulated, otherwise the equipment will be damaged.

### 連接安全繼電器G9SA的安全回路範例 Circuit Diagram for connecting safety relay G9SA

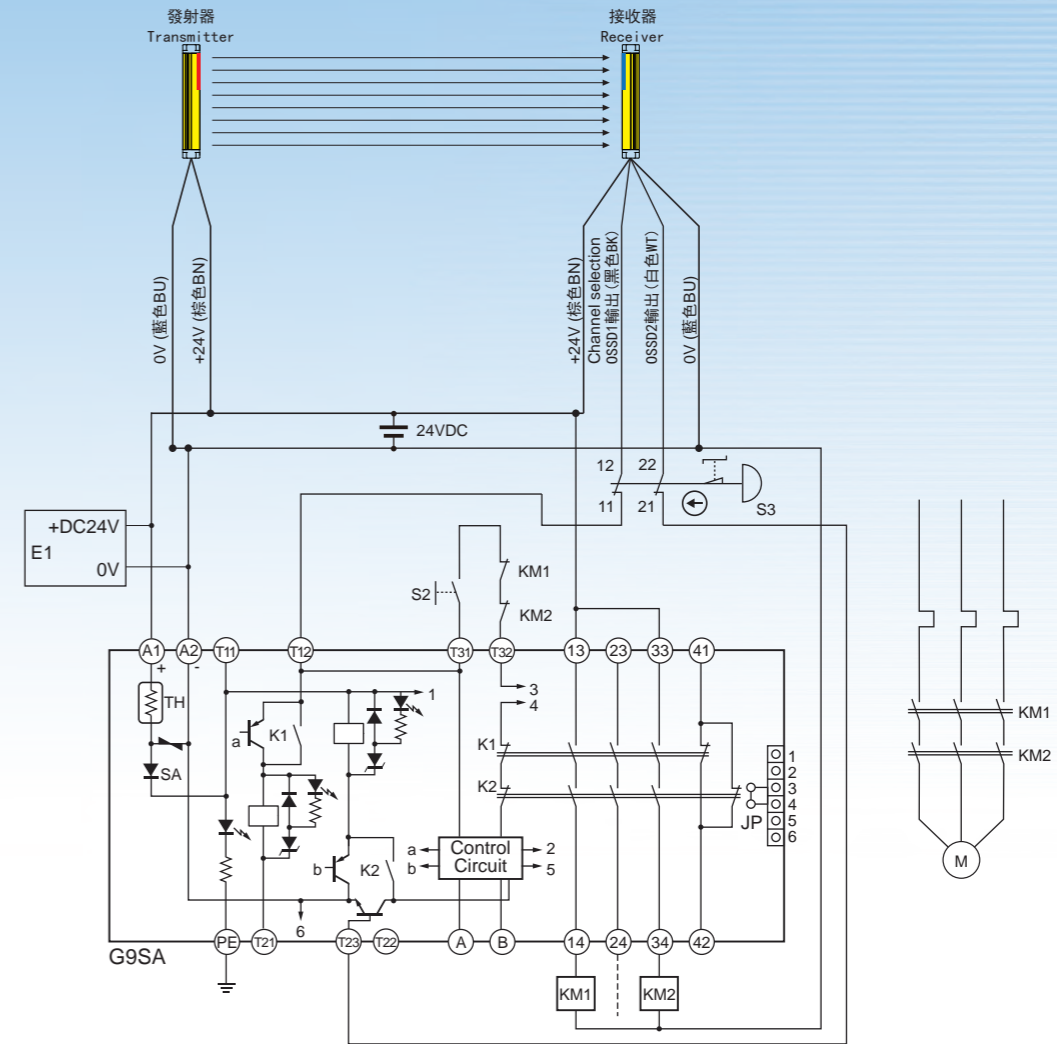

\*1. 不使用緊急停止按鈕時，請直接連接OSSD1輸出與T12端子、以及OSSD2輸出與T23端子。  
If an emergency stop switch is not used, connect OSSD1 output to T12 terminal and OSSD2 output to T23 directly.

- S2: 復歸開關 Interlock reset switch
- S3: 緊急停止開關 Emergency stop switch
- KM1、KM2: 電磁接觸器 Safety relay with force-guided contact (G7SA) or magnetic contactor
- M: 3相馬達 3-phase motor
- E1: DC24V電源供應器 Power supply

# 包材尺寸與重量 Packaging Size and Weight

單位 Unit: mm, kg

產品編號 Model	品名 Product Name	本體總長 Body Length	包裝 Package	一組包裝尺寸 Packaging sizes of one set	毛重 Gross weight	外箱尺寸 Carton size L*W*H	外箱重量 Carton weight	外箱最大包裝數量 The max number of carton packaging
<b>棒型 Bar Type</b>								
MESD-BC036	036薄型靜電消除器	356	紙盒 Carton	396*119*121	1.1	416*383*266	0.9	6set
MESD-BC060	060薄型靜電消除器	490		573*119*121	1.3	593*383*266	1.1	6set
MESD-BC084	084薄型靜電消除器	723		813*119*121	1.5	833*383*266	1.3	6set
MESD-BC108	108薄型靜電消除器	956		1053*119*121	1.95	1075*383*266	1.5	6set
MESD-BC132	132薄型靜電消除器	1189	紙管 Paper Tube	1520 * $\varnothing$ 99	3.3			
MESD-BC156	156薄型靜電消除器	1422		2000 * $\varnothing$ 99	4.2			
MESD-BC180	180薄型靜電消除器	1655		2000 * $\varnothing$ 99	4.5			
MESD-BC204	204薄型靜電消除器	1888		2500 * $\varnothing$ 99	5.2			
MESD-BC228	228薄型靜電消除器	2121		2500 * $\varnothing$ 99	5.4			
MESD-BC252	252薄型靜電消除器	2354		2720 * $\varnothing$ 99	6.0			
<b>扇型 Fan Type</b>								
MESD-FA04	4吋扇形靜電消除器	130*176*77	紙盒 Carton	250*220*100	1.3	593*383*266	1.1	7set
MESD-FA05A	5吋扇形靜電消除器	140*200*75		260*230*90	1.6	488*295*201	0.6	4set
MESD-FA05E	5吋扇形高頻靜電消除器			260*230*90	1.7	593*383*266	1.1	9set
<b>管型 Tube Type</b>								
MESD-1HA	單管型靜電消除器	92*30*60	紙盒 Carton	190*130*50	0.3	408*295*201	0.6	12set
MESD-2HA	雙管靜電消除器	92*65*60				250*220*100	0.7	
MESD-F100L	100L可撓管形噴嘴組	121	實體 Entity	130*30*30	0.1			
MESD-F200L	200L可撓管形噴嘴組	221		220*30*30	0.2			
MESD-F300L	300L可撓管形噴嘴組	321		320*30*30	0.25			
MESD-S100L	100L棒型噴嘴組	169		180*30*30	0.1			
MESD-S200L	200L棒型噴嘴組	269		270*30*30	0.2			
MESD-S300L	300L棒型噴嘴組	369		380*30*30	0.3			
MESD-NSTA	標準型噴嘴組			50*30*30	0.05			
<b>其它 Other</b>								
MESD-GA	槍型靜電消除器		紙盒 Carton	260*230*90	0.7			
MESD-NA060	空間型靜電消除器	490		573*119*121	1.9	593*383*266	1.1	6set
TREK-511	手持式靜電測量儀	60*106*20		280*265*55	0.35			
MPWR-ZA03015	靜電產生器			408*295*201	1.4			
<b>配件 Accessories</b>								
MESD-CP060E	電源供應器60W(棒型用)		夾鏈袋 Zipper bag	140*80*40	0.8			
MESD-CP025C	電源供應器24W(管型用)			140*80*40	0.5	416*383*266	0.9	42set
MESD-FA04ECNM01	4吋靜電風扇放電針組	50個/盒	塑膠盒 Plastic box	105*80*55	0.1	225*195*160	0.5	400pcs

單位 Unit: mm, kg

產品編號 Model	品名 Product Name	本體總長 Body Length	包裝 Package	一組包裝尺寸 Packaging sizes of one set	毛重 Gross weight	外箱尺寸 Carton size L*W*H	外箱重量 Carton weight	外箱最大包裝數量 The max number of carton packaging
<b>安全光柵-標準型 Safety Light Curtains - Standard Type</b>								
SLC-08	安全光柵08B光軸	193	紙盒 Carton	385*89*88	0.62	408*295*201	0.6	6set
SLC-12	安全光柵12B光軸	273		465*89*88	0.68	408*295*201	0.6	6set
SLC-16	安全光柵16B光軸	353		535*89*89	0.75	488*295*201	0.7	6set
SLC-20	安全光柵20B光軸	433		695*89*89	0.84			
SLC-24	安全光柵24B光軸	513		695*89*89	0.95			
SLC-28	安全光柵28B光軸	593		930*89*89	1.10			
SLC-32	安全光柵32B光軸	673		930*89*89	1.20			
SLC-36	安全光柵36B光軸	753	930*89*89	1.33				
SLC-40	安全光柵40B光軸	833	紙管 Paper Tube	1070* $\varnothing$ 99	1.48			
SLC-44	安全光柵44B光軸	913		1230* $\varnothing$ 99	2.31			
SLC-48	安全光柵48B光軸	993		1230* $\varnothing$ 99	2.47			
SLC-52	安全光柵52B光軸	1073		1230* $\varnothing$ 99	2.81			
SLC-56	安全光柵56B光軸	1153		1390* $\varnothing$ 99	2.95			
SLC-60	安全光柵60B光軸	1233		1520* $\varnothing$ 99	3.06			
SLC-64	安全光柵64B光軸	1313		1520* $\varnothing$ 99	3.20			

## 外觀尺寸 External Dimensions

單位 Unit: mm

▶ 紙管 Paper Tube

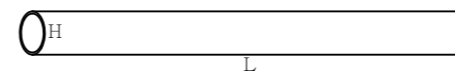

▶ 紙盒 Carton

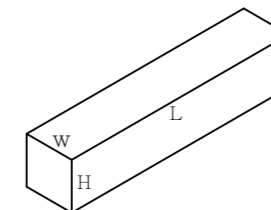

▶ 外紙箱 Package Carton

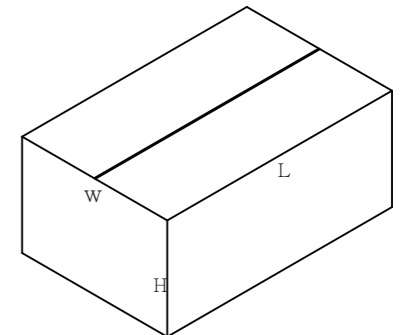

包材尺寸與重量 Packaging Size and Weight